

PEI HWA PRESBYTERIAN PRIMARY SCHOOL
PRELIMINARY EXAMINATION

PRIMARY 6
SCIENCE
(BOOKLET A)

23rd AUGUST 2021

Name: _____ ()

Class: Resilience _____

Total time for Booklets A and B: 1 h 45 min

INSTRUCTIONS TO CANDIDATES

1. Write your Name, Class and Register No. in the spaces provided above.
2. DO NOT turn over this page until you are told to do so.
3. Follow all instructions carefully.
4. Answer all questions.
5. Shade your answers on the Optical Answer Sheet (OAS) provided.

This booklet consists of 19 printed pages, excluding the cover page.

For each question from 1 to 28, four options are given. One of them is the correct answer. Make your choice and shade the oval (1, 2, 3 or 4) on the Optical Answer Sheet provided. (56 marks)

- 1 Eunice poured an equal amount of water at 5°C into four identical cups made of four different materials. She recorded the temperature of the water in the graph below.

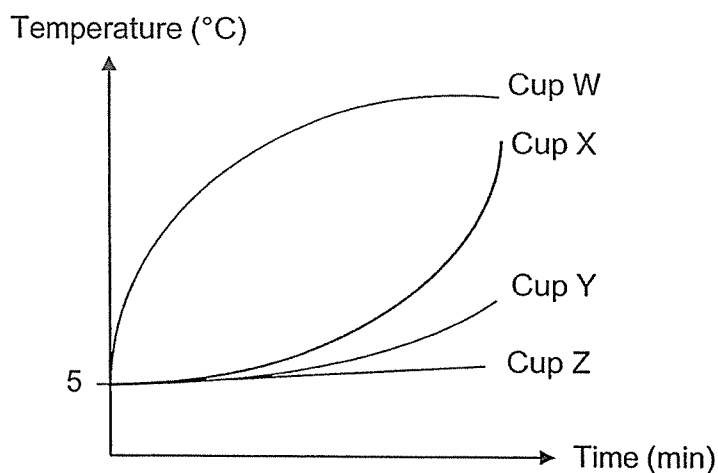

Which cup, W, X, Y or Z, is most suitable to keep a drink hot for the longest time?

- (1) W
(2) X
(3) Y
(4) Z
- 2 The statements below show the different processes that take place in a digestive system.
- A After water is removed, the undigested food is passed out of the body.
B Food in the mouth is chewed into smaller pieces and mixed with saliva.
C Food moves from mouth to stomach through the gullet.
D The food is digested and then absorbed in the small intestine.

Rearrange the statements to show the correct order of the digestion process.

- (1) B → D → A → C
(2) B → C → D → A
(3) C → B → D → A
(4) C → B → A → D

3 The table below shows 2 groups of living things.

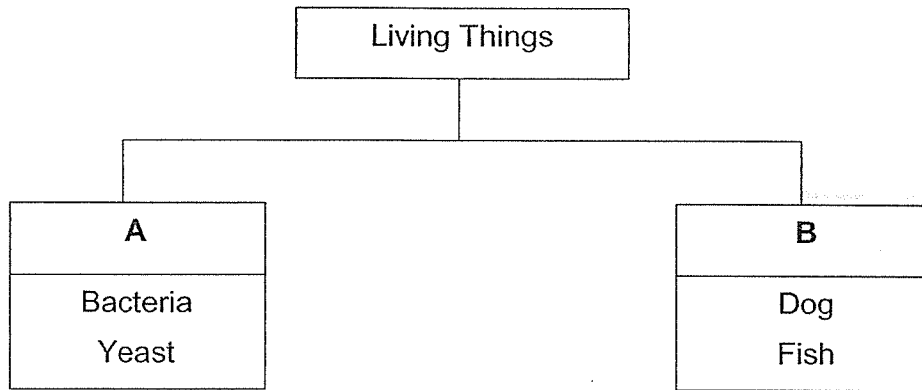

Which of the following are suitable headings for A and B?

	A	B
(1)	Cannot grow	Can grow
(2)	Can make food	Cannot make food
(3)	Cannot reproduce	Can reproduce
(4)	Single-cell organism	Multi-cell organism

4 The diagram below shows the life cycle of a beetle.

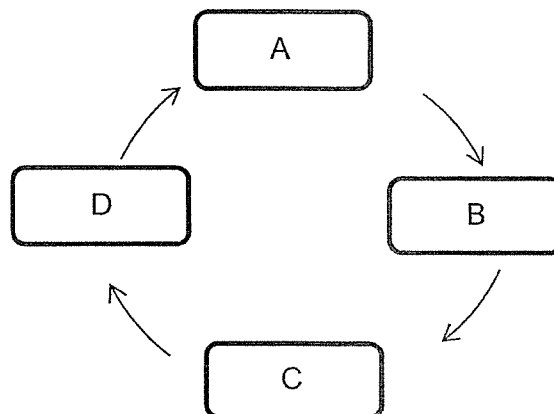

Which of the following correctly shows the different stages of its life cycle?

	A	B	C	D
(1)	Egg	Pupa	Larva	Adult
(2)	Larva	Pupa	Egg	Adult
(3)	Larva	Adult	Egg	Pupa
(4)	Adult	Egg	Larva	Pupa

- 5 Two objects, Y and Z, were brought close to a magnet as shown below.

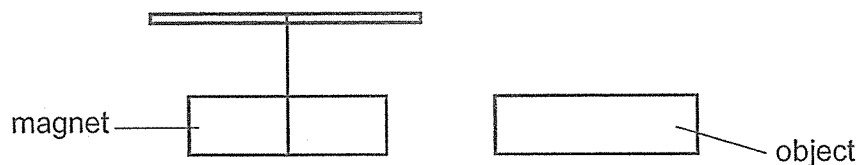

When object Y was brought near the magnet, it was attracted to the magnet.
When object Z was brought near the magnet, it was attracted to the magnet.

Which of the following are possible observations when objects Y and Z are brought close to each other?

- A They will be repelled.
 - B They will be attracted.
 - C There will be no interaction.
-
- (1) A and B only
 - (2) A and C only
 - (3) B and C only
 - (4) A, B and C

- 6 Ben carried out an experiment to find out whether light can pass through certain materials. He set up the experiment in a dark room.

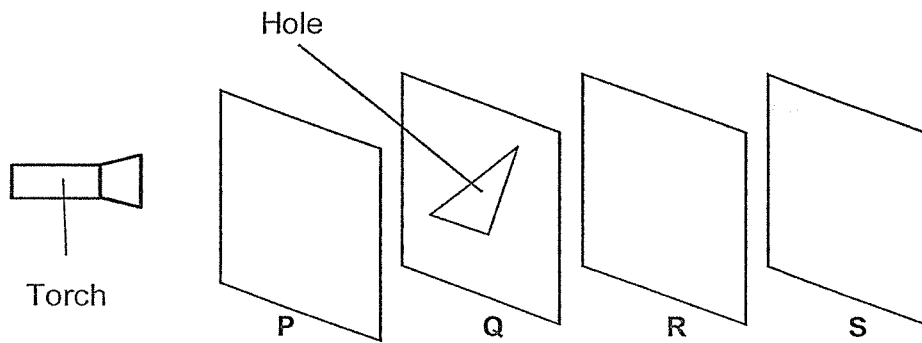

He arranged 4 sheets of different materials, P, Q, R and S, one behind another in a straight line. He also cut a hole in sheet Q before shining the torch at sheet P. He observed a bright triangular patch of light on sheet R.

Based on the experiment, what can be concluded about the four sheets of materials?

	Allows light to pass through	Does not allow light to pass through	Not possible to tell
(1)	Q	R	P and S
(2)	P	Q and R	S
(3)	R and S	P	Q
(4)	P, Q and R	None	S

- 7 John set up an experiment as shown in the diagram below. When he placed the test tube into a beaker of ice cubes, the ink in the glass tube rose first then fell.

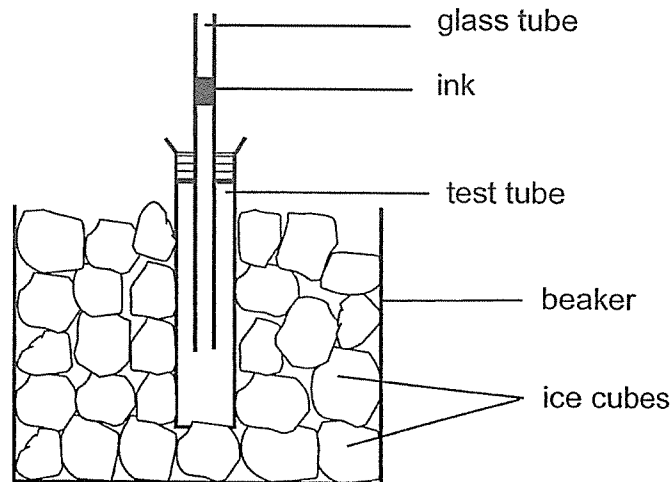

Which of the following statements is true?

- (1) The test tube contracted before the beaker contracted.
 - (2) The ink expanded before the air in the test tube contracted.
 - (3) The air in the test tube contracted before the test tube contracted.
 - (4) The test tube contracted before the air in the test tube contracted.
- 8 Which of the following statement(s) is/are true about both the reproduction of flowering plants and humans?
- A Pollination occurs before fertilisation.
 - B Fertilisation takes place in the ovary.
 - C The male sex cells are produced in the testes.
 - D Fertilisation occurs when the male sex cell fuses with the female sex cell.
- (1) D only
 - (2) A and C only
 - (3) B and D only
 - (4) A, B, C and D

- 9 Bob wanted to find out how the speed of wind would affect the rate of evaporation of water. He poured equal amounts of water into three containers, P, Q and R. A similar fan was placed above each container and turned on at the beginning of the experiment.

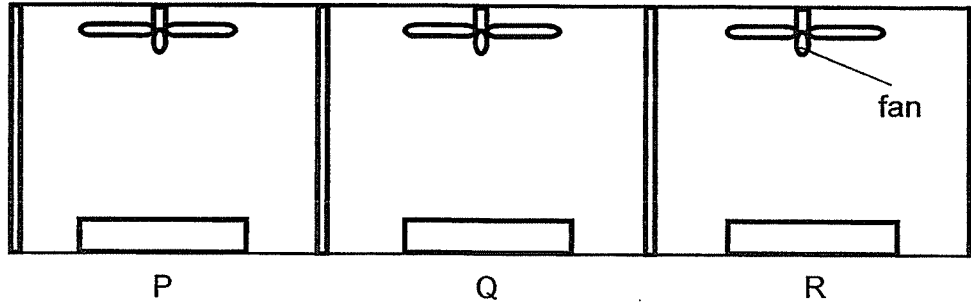

He measured the volume of water in each container after some time and recorded the results.

What is/are the variable(s) that should be kept the same for the experiment to be fair?

- A Rate of evaporation of water
 - B Amount of water left in the container
 - C Exposed surfaced area of each container
 - D Number of turns made by the fan per minute
- (1) C only
- (2) C and D only
- (3) A, B and C only
- (4) A, B, C and D

10 The graph below shows changes in variable X in a country over a period of time.

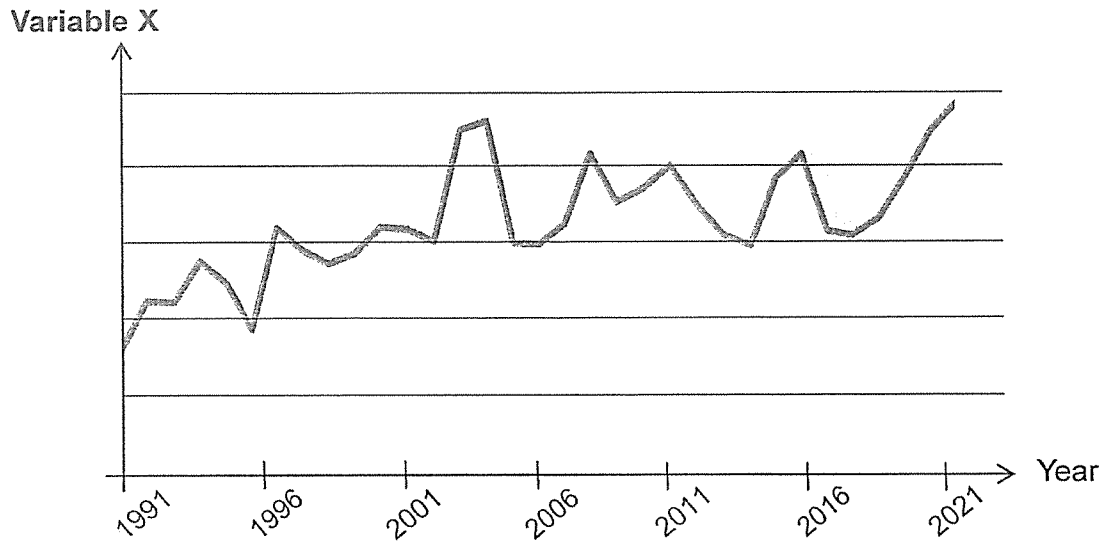

It was concluded that the rate of evaporation increased from 1991 to 2021 as a result of variable X as shown in the graph. What is variable X?

- (1) Area of land
 - (2) Amount of light
 - (3) Amount of water
 - (4) Temperature of surrounding
- 11 Which of the following statement(s) about the plant transport system and the human circulatory system is/are true?
- A Both systems circulate all substances in one direction.
 - B Both systems transport only water to all parts of the organisms.
 - C Both systems transport substances to all parts of the organisms.
 - D Both systems are made up of only tubes to transport substances.
- (1) C only
 - (2) A and B only
 - (3) C and D only
 - (4) B, C and D only

- 12 Study the circuit below. Bulbs A, B, C, D and E are identical bulbs with equal brightness.

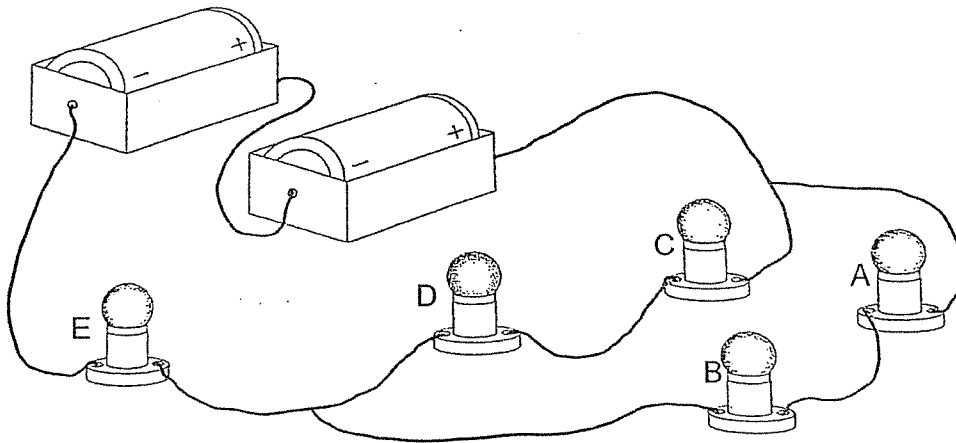

Which 2 bulbs should be removed so that the remaining 3 bulbs light up with equal brightness?

- (1) A and D
 - (2) B and C
 - (3) C and D
 - (4) D and E
- 13 Gary placed a magnet close to object A. He observed that object A moved, hit object B and stopped moving. Then, object B moved as shown in the diagram below.

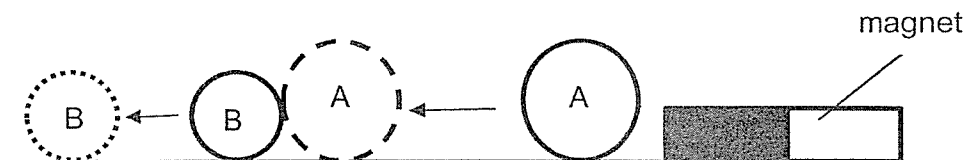

Which of the following shows the correct forces acting on object B when it was moving?

	Gravitational force	Magnetic force	Frictional force
(1)	✓	✓	
(2)	✓		✓
(3)		✓	✓
(4)	✓	✓	✓

14 Which one of the graphs correctly shows the relationship between the amount of kinetic energy an object has and the speed of the object?

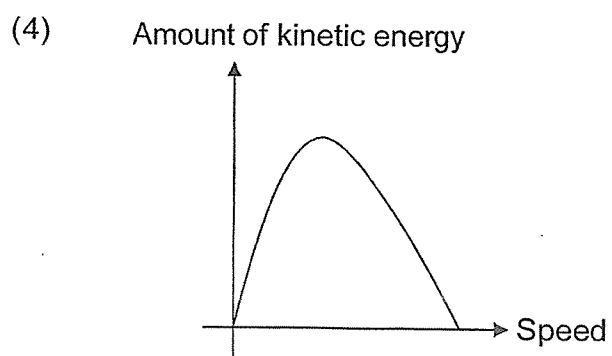
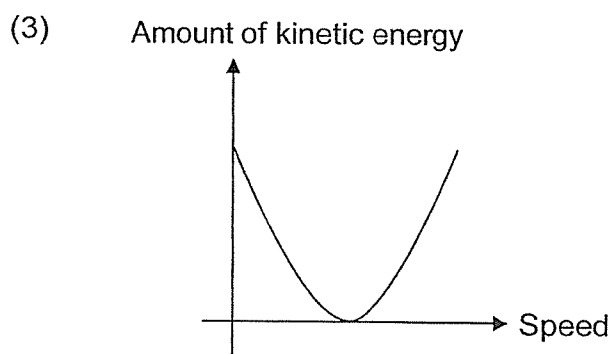
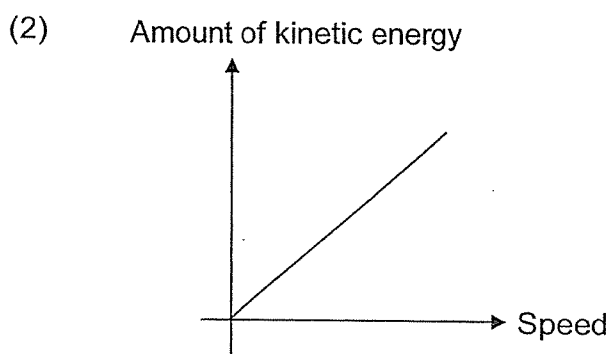
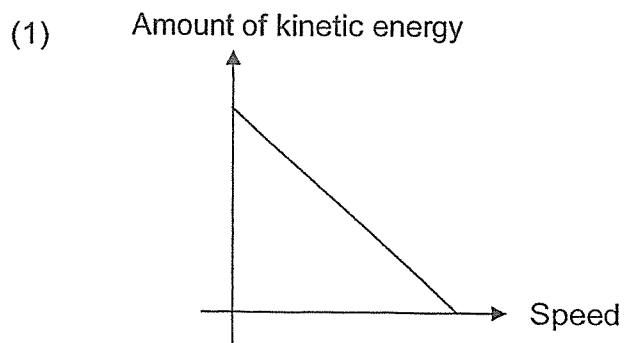

- 15 Tom threw a ball upwards as shown in the diagram below. The ball moved from A to B and back to A.

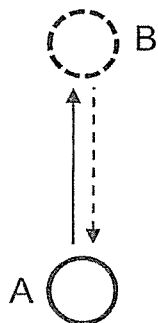

Which of the following graphs correctly shows the amount of potential energy and the kinetic energy of the ball at B?

(1)

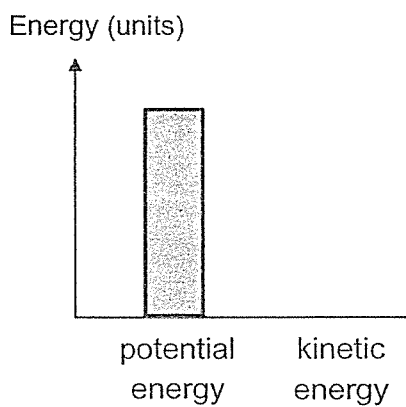

(2)

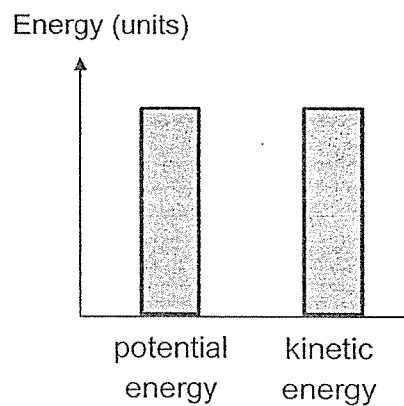

(3)

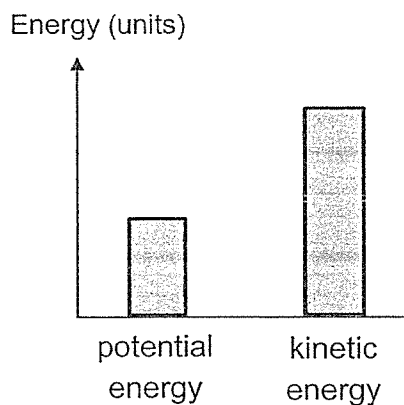

(4)

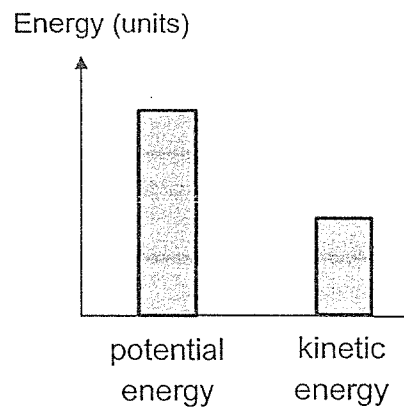

16 Which of the following are produced by plants during photosynthesis?

- A sugar
- B starch
- C oxygen
- D carbon dioxide

- (1) A and C only
- (2) B and C only
- (3) A and D only
- (4) B and D only

17 The diagram below shows a plant in a dark room.

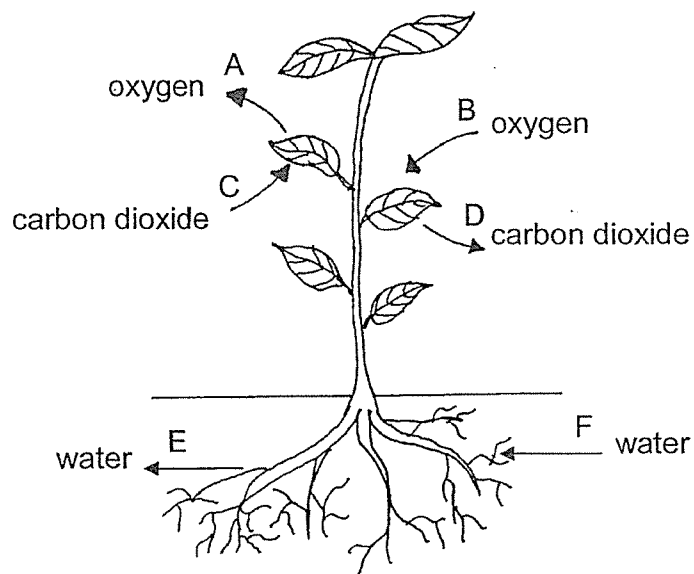

Which of the following arrows correctly show the movement of gases and water of the plant?

- (1) A, C and E only
- (2) A, C and F only
- (3) B, D and F only
- (4) A, B, C, D and F only

18 Jan placed a water plant in a beaker filled with water as shown in the diagram below.

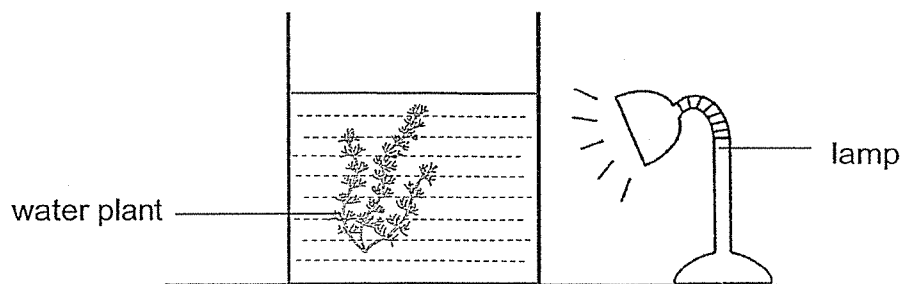

She placed a lamp beside the beaker and measured the amount of dissolved oxygen in the water. The results are shown in the graph below.

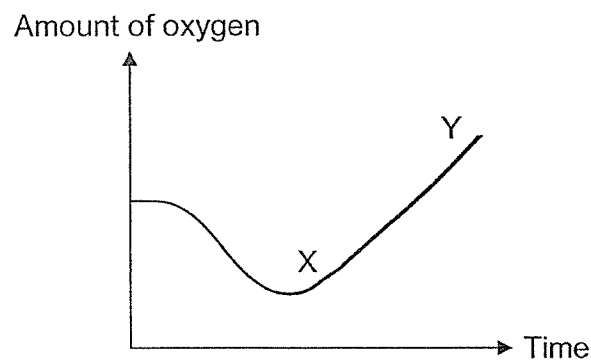

Which of the following could be the possible reason(s) for the change in amount of oxygen from X to Y?

- A Add more water into the beaker.
- B Add more plants into the beaker.
- C Increase the distance between the lamp and the beaker.

- (1) B only
- (2) A and C only
- (3) B and C only
- (4) A, B and C

19 The diagram below shows a ball rolling on the ground.

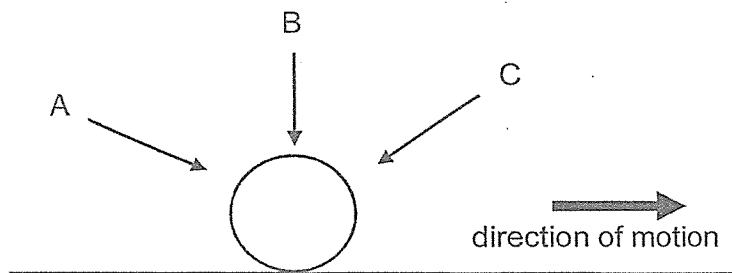

Which force(s), A, B or C, can be applied to decrease the speed of the ball?

- (1) B only
- (2) C only
- (3) B and C only
- (4) A, B and C

20 Felicia carried out an experiment as shown below.

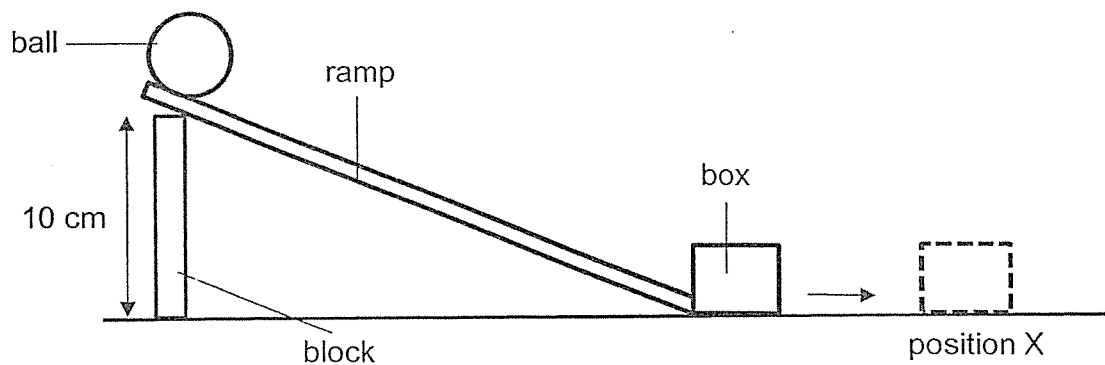

When she released the ball, it rolled down and hit the box. The box then moved to position X. What could she do to the set-up so that the box will move further than position X?

- A Put oil on the ramp.
- B Release the ball at a lower point.
- C Use a bigger ball of the same mass.
- D Use a block of height 12 cm to support the ramp.

- (1) A only
- (2) B and C only
- (3) A and D only
- (4) C and D only

21 Melvin performed the following tasks.

- A Push a 6 kg box of cotton up a slope over a distance of 3 m.
- B Push a 6 kg box of cotton on a flat ground over a distance of 3 m.
- C Push a 5 kg box of stones on a flat ground over a distance of 3 m.
- D Push a 5 kg box of stones in a trolley on a flat ground over a distance of 3 m.

Arrange the following tasks according to the amount of force required to push the box, starting with the least amount of force.

	Least force	—————▶	Most force
(1)	A	B	C
(2)	B	C	D
(3)	D	C	B
(4)	D	B	A

22 Peter wanted to find out how overcrowding affects the growth of a plant. Which set-ups should he use for his experiment?

Set-up	Distance between each plant (cm)	Number of plant	Area of soil (m ²)
A	5	10	20
B	15	10	10
C	15	3	10
D	20	5	10
E	25	5	10
F	30	5	10
G	50	3	20

- (1) B, C and D only
- (2) B, F and G only
- (3) D, E and F only
- (4) A, B, C, D, E, F and G only

23 The diagram below shows a green plant.

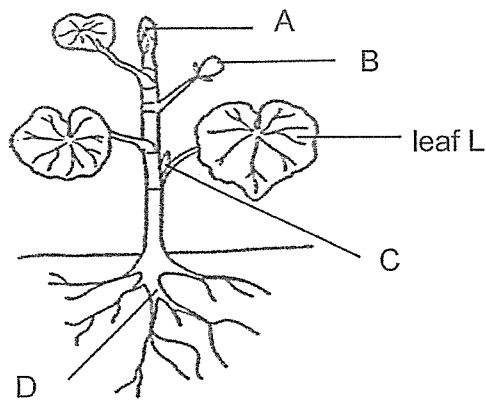

Food made by leaf L could be found at _____.

- (1) A and B only
 - (2) C and D only
 - (3) B, C and D only
 - (4) A, B, C and D
- 24 Jeremy set up an experiment as shown in the diagram below. When he released the toy car, it started moving along the track from A down to B, up to C, before leaving at D.

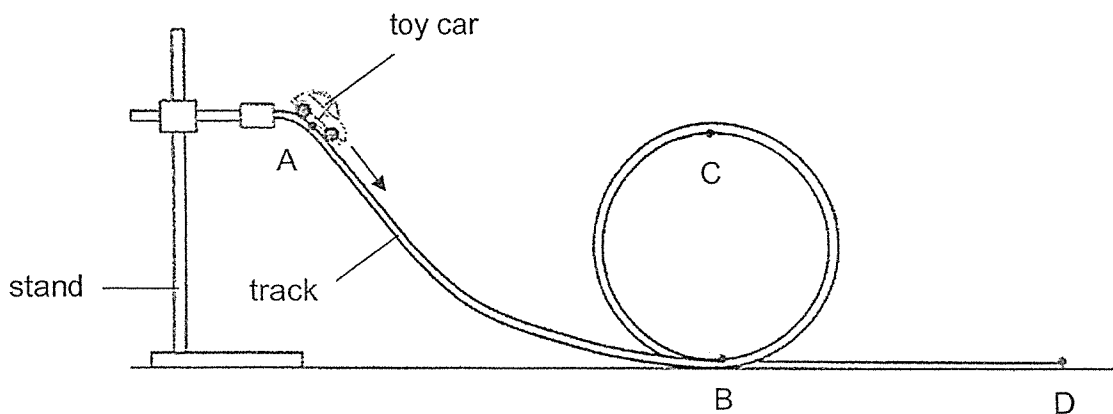

At which points of the track would the amount of gravitational force acting on the toy car be the same?

- (1) A and C
- (2) B and D
- (3) B and C
- (4) A, B, C and D

25 Which one of the following shows the processes in the sexual reproduction of a flowering plant arranged in the correct order?

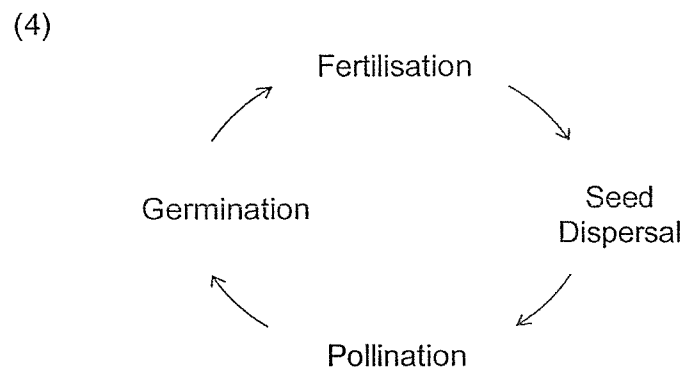
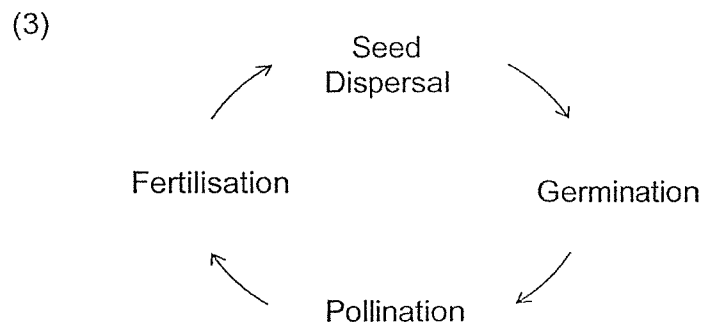
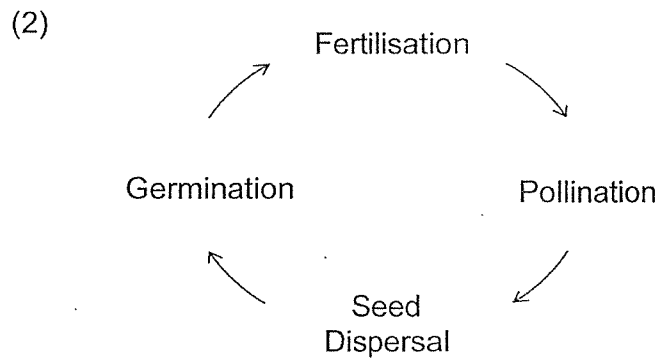
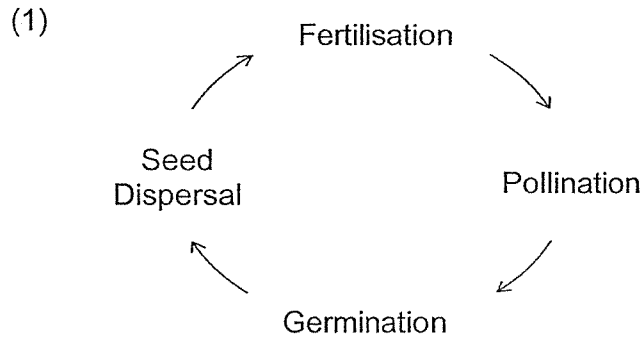

26 Sam set up an experiment as shown in the diagram below.

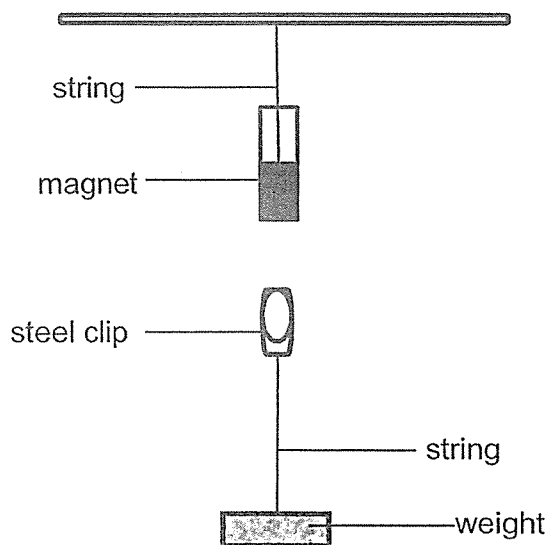

Based on the experiment, what can he conclude?

- A Magnetic force can act from a distance.
- B Like poles repel and unlike poles attract.
- C The pole of a magnet has the strongest magnetic force.
- D Magnetic force acting on the steel clip is greater than the gravitational force.

- (1) A only
- (2) A and D only
- (3) B and C only
- (4) A, C and D only

27 Ben removed the food-carrying tubes of a plant as shown in the diagram below.

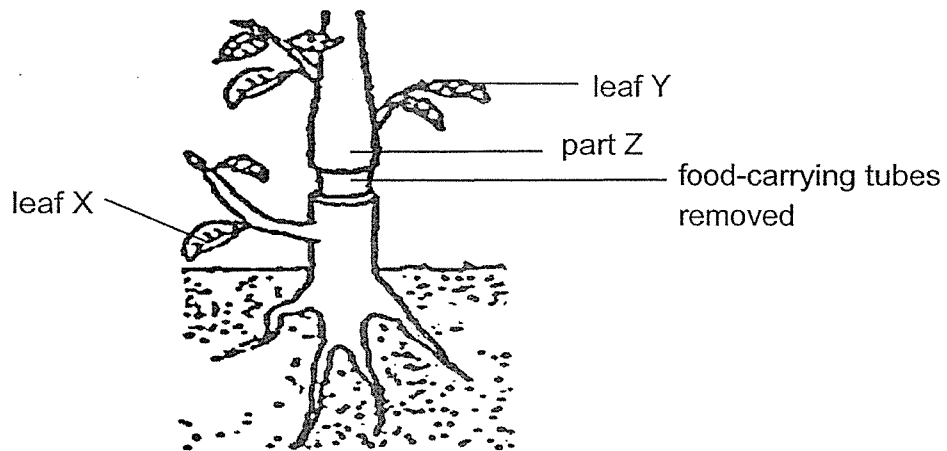

He observed the plant after two weeks. Which of the following observation(s) is/are true?

- A Leaf X will die.
- B Part Z will swell up.
- C Leaf Y will remain green.

- (1) B only
- (2) B and C only
- (3) A and B only
- (4) A, B and C

28 The diagrams below show the enlarged diagram of parts of the plant and fish.

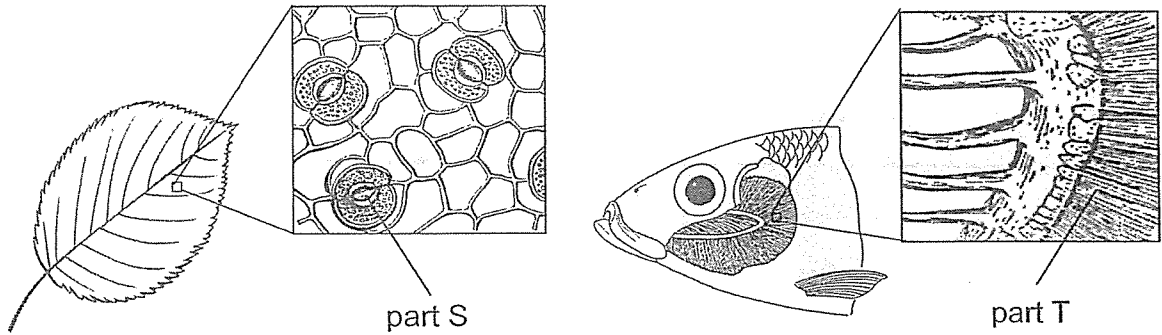

Which of the following about both part S and T is/are true?

- A They allow gaseous exchange.
- B They need food in order to function.
- C Part S functions only in the presence of light while part T functions all the time.

- (1) B only
- (2) A and B only
- (3) B and C only
- (4) A, B and C

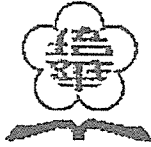

PEI HWA PRESBYTERIAN PRIMARY SCHOOL
PRELIMINARY EXAMINATION

PRIMARY 6
SCIENCE
(BOOKLET B)

23rd AUGUST 2021

Name: _____ ()

Class: Resilience _____

Parent's Signature

Total time for Booklets A and B: 1 h 45 min

INSTRUCTIONS TO CANDIDATES

1. Write your Name, Class and Register No. in the spaces provided above.
2. DO NOT turn over this page until you are told to do so.
3. Follow all instructions carefully.
4. Answer all questions.
5. Write all your answers in this booklet.

Marks (Booklet A) :	56
Marks (Booklet B) :	44
Total Marks (Booklets A & B) :	100

This booklet consists of 18 printed pages, excluding the cover page.

Write your answers to the questions 29 to 41 in the spaces provided. The number of marks available is shown in bracket [] at the end of each question or part question. (44 marks)

29 The picture below shows a raincoat, which is worn on rainy days.

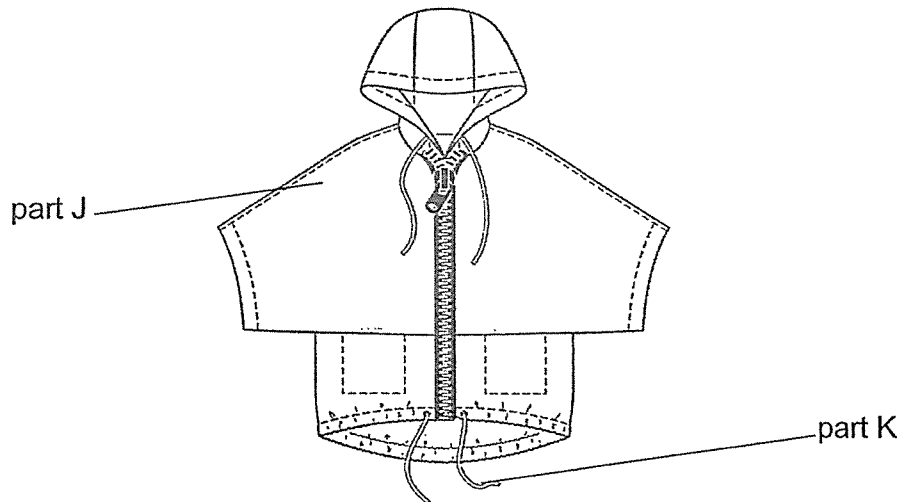

- (a) Which material is suitable to make part J of the jacket? Give a reason for your answer.

[1]

- (b) State a property of material that allows part K to be tied into a knot.

[1]

30 The diagram below shows the movement of blood to and from the human heart.

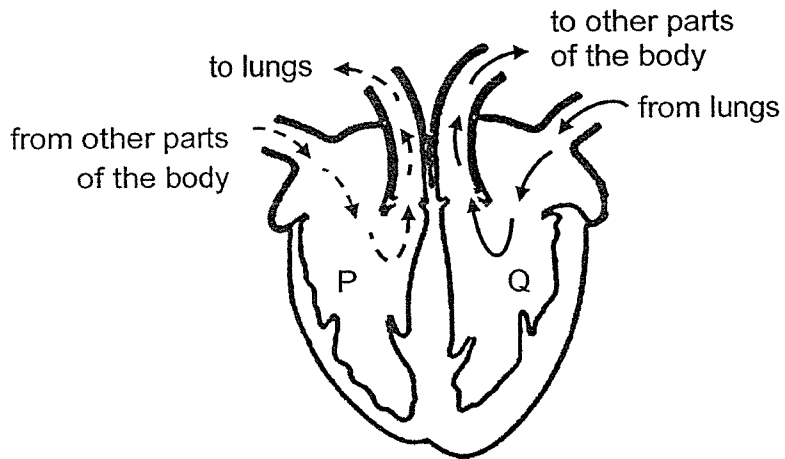

(a) Identify the gases which blood in area P and Q are rich in. [1]

P: _____

Q: _____

(b) State the function of the blood vessels. [1]

- 31 The graph below shows the mass of the different stages of the life cycle of Animal X over time.

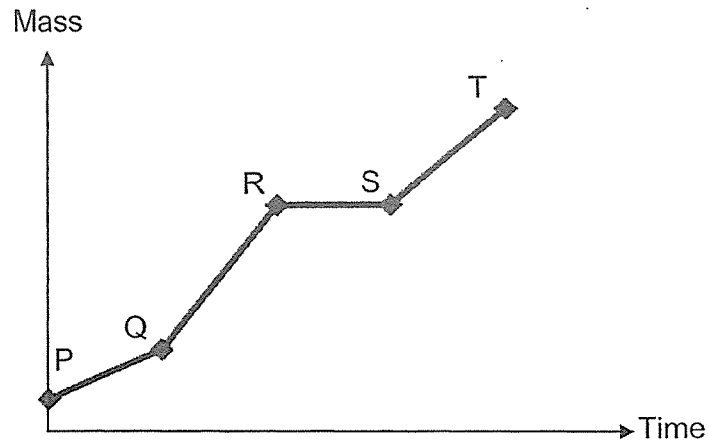

- (a) How many stages are there in the life cycle of Animal X? [1]

- (b) What happens to the mass of Animal X at line RS? Give a reason why. [1]

- (c) Name an example of Animal X. [1]

32 The diagram below shows a part of a school library.

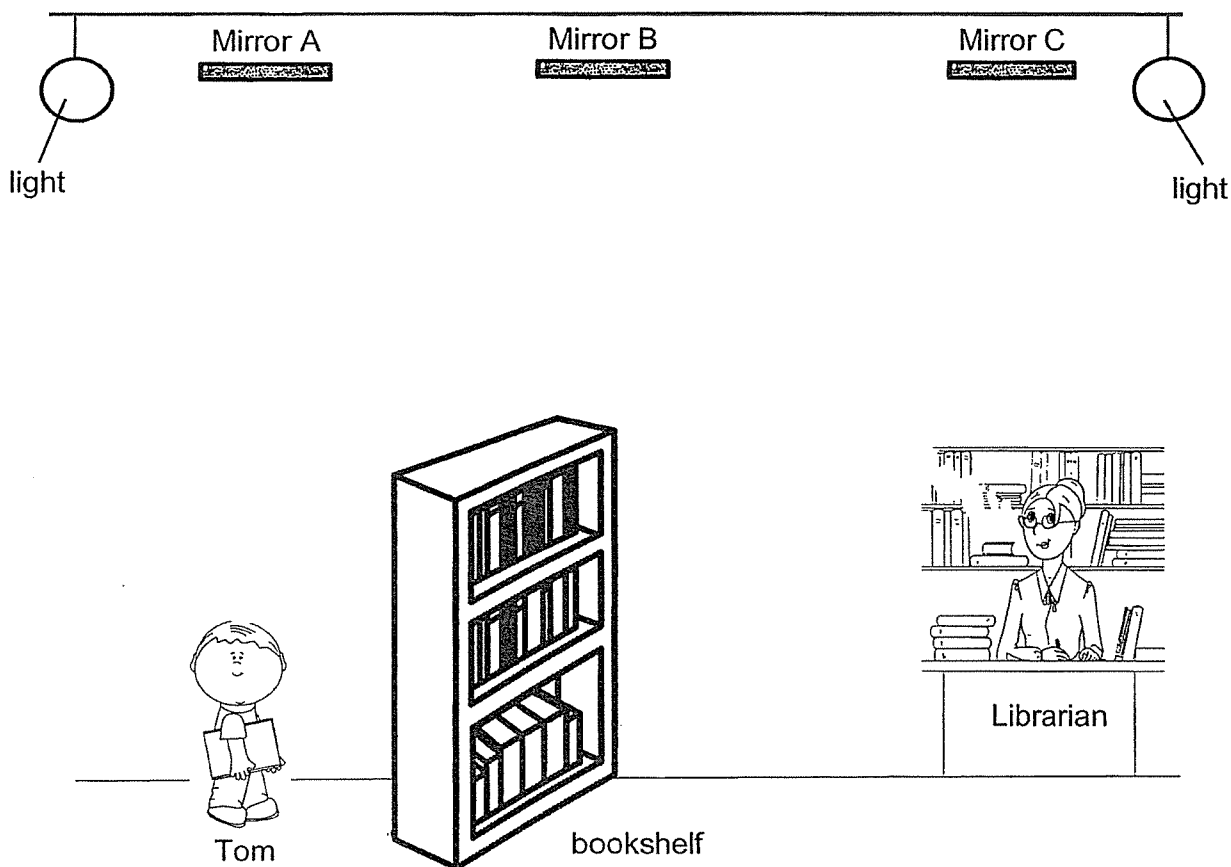

- (a) Which mirror(s), A, B and/or C, allows the librarian to see Tom behind the bookshelf? [1]

- (b) On the diagram above, draw arrows to represent the path of light which allowed the librarian to see Tom. [1]

- (c) Tom noticed that there were more than one shadow of him on the floor. Give a reason why. [1]

33 (a) State what is temperature.

[1]

(b) Nat placed a temperature sensor into 2 flasks, A and B as shown in the diagram below.

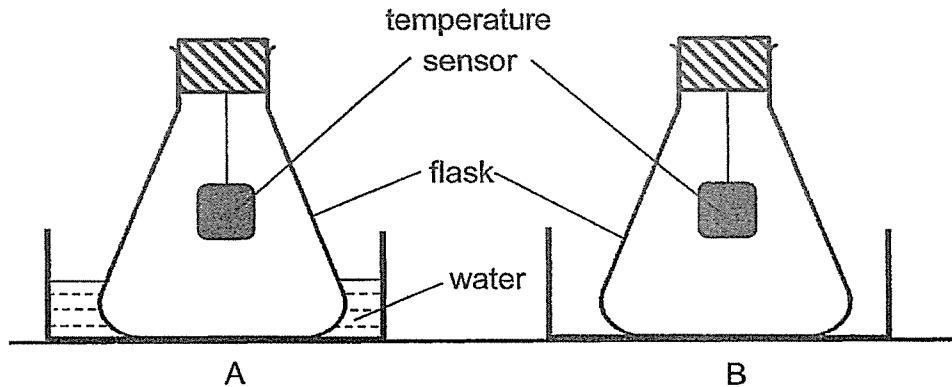

He measured the temperature in the flasks and recorded the results in the table below.

Time (min)	Temperature in flask (°C)	
	A	B
0	28	28
20	25	28
40	28	28
60	28	28
80	28	28

(i) Suggest one improvement to the experiment to obtain more accurate results.

[1]

Question 33 continues on next page

(ii) Animal P are often seen dipping in waters.

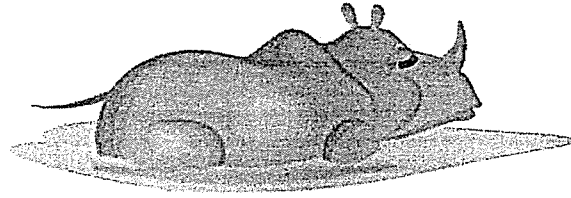

Based on the above experiment, explain how being in the water helps animal P on hot days. [1]

34 Study Fruits X and Y below.

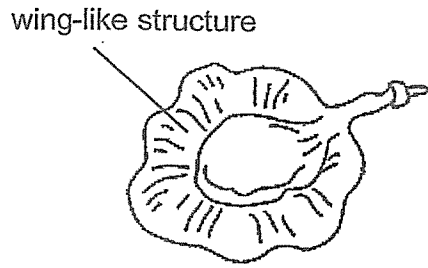

Fruit X

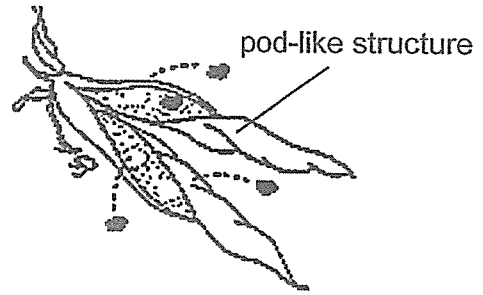

Fruit Y

- (a) Identify the dispersal methods and explain how the labelled characteristics of the fruits help the seeds to be dispersed. [2]

Fruit	Dispersal method	How does the labelled characteristic help the seed disperse?
X		
Y		

- (b) Explain why plants growing far apart from one another benefits the plants. [1]

- 35 John carried out an experiment using 3 containers, X, Y and Z. He filled containers X and Z with limewater and placed animal R in container Y as shown in the diagram below.

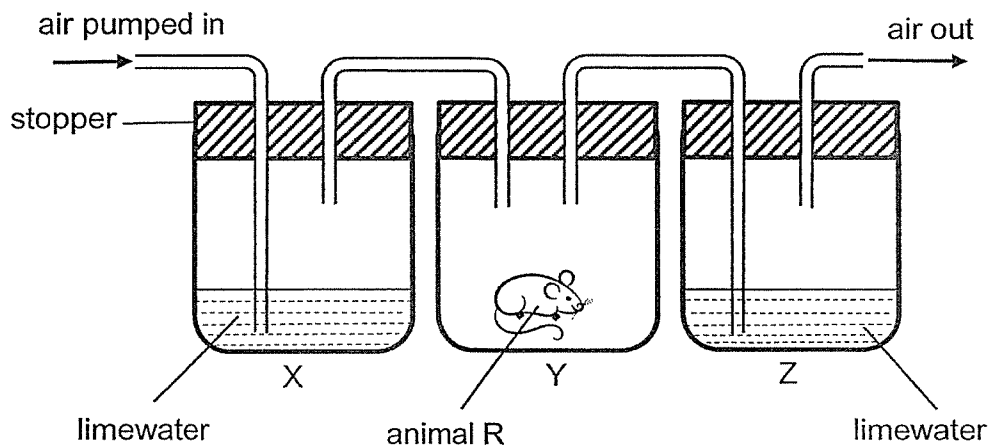

Limewater turns chalky in the presence of carbon dioxide and remains clear when there is little or no carbon dioxide.

John observed the limewater in the containers after some time.

- (a) What was the aim of the experiment? [1]

- (b) Each of the following statements below is either true, false or not possible to tell. For each statement, put a tick (✓) to indicate your answer. [2]

Statement	True	False	Not possible to tell
There is no oxygen in container Z.			
The limewater in container Z is more chalky than container X.			
The amount of water vapour in container X is less than the amount of water vapour in container Z.			

Question 35 continues on next page

- (c) John's father told him that he should prepare a control setup for his experiment. What is the purpose of the control setup? [1]

- (d) In the diagram below, draw and label the content in the control setup for the experiment. [1]

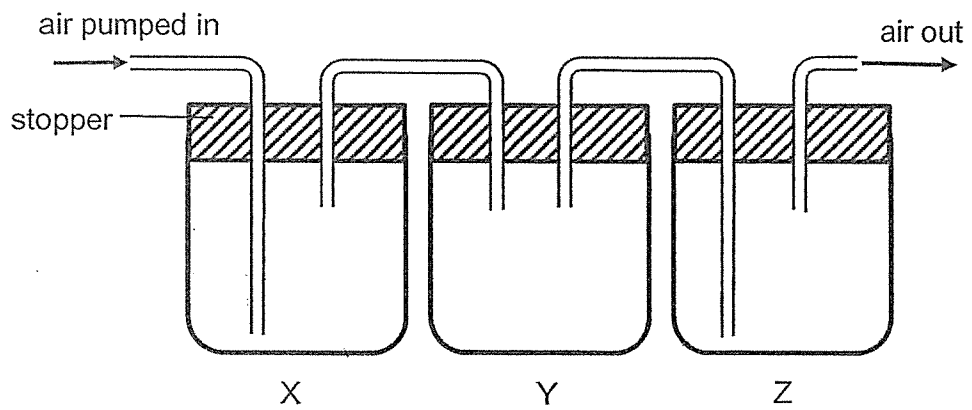

- 36 The diagram below shows a spiral paper on a stand, hanging on top of a heater. When the heater was switched on, the spiral paper started to spin.

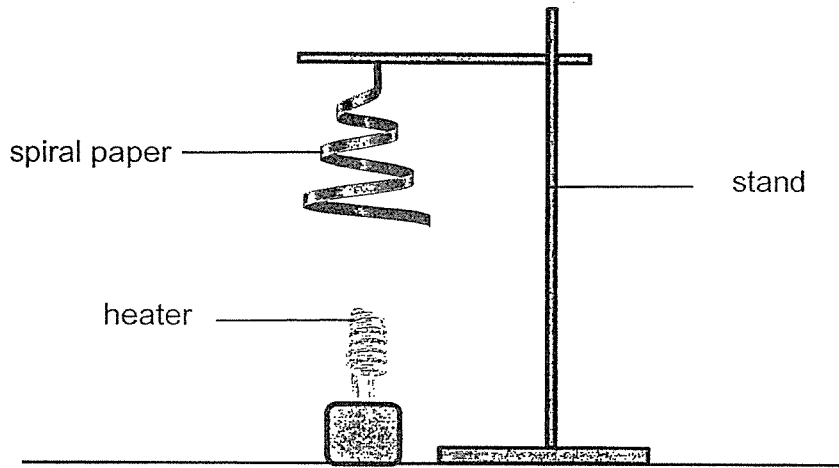

- (a) Complete the energy conversion that caused the spiral paper to spin when the heater was switched on. [1]

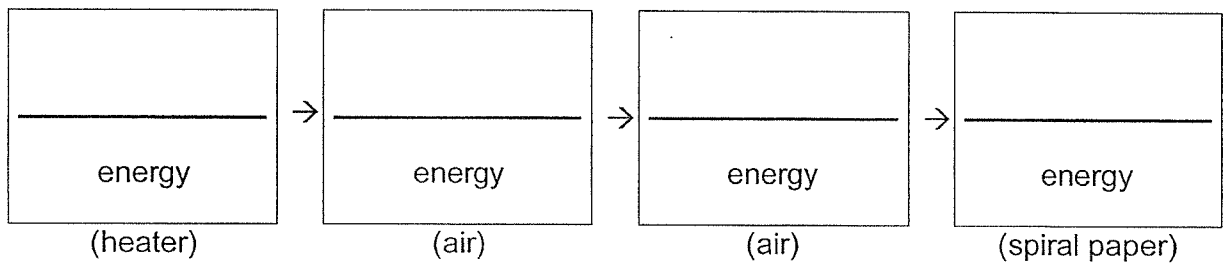

- (b) Predict what would happen when the temperature of the heater was increased. Explain your answer. [2]

- 37 Rex wanted to find out how the amount of light affects the rate of photosynthesis. He set up an experiment as shown in the diagram below.

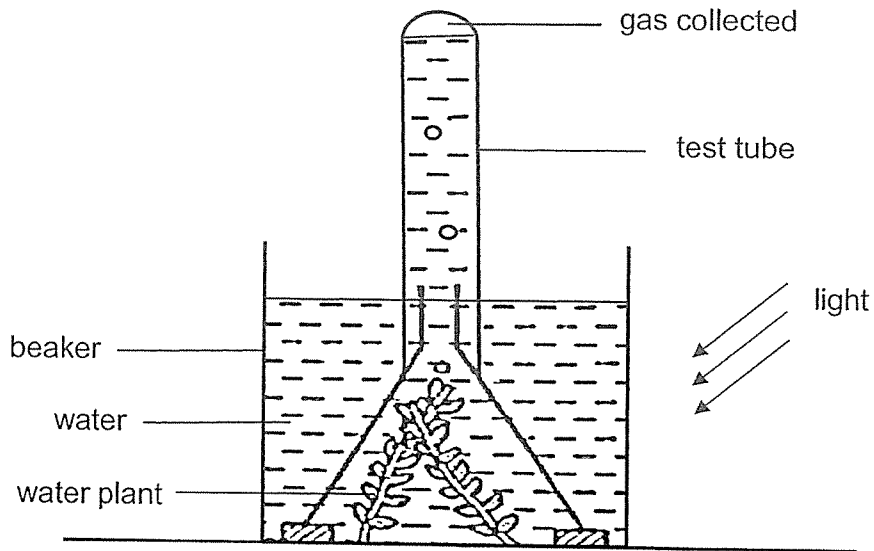

He changed the amount of light given to the plant, measured the amount of gas collected and recorded the results as shown below.

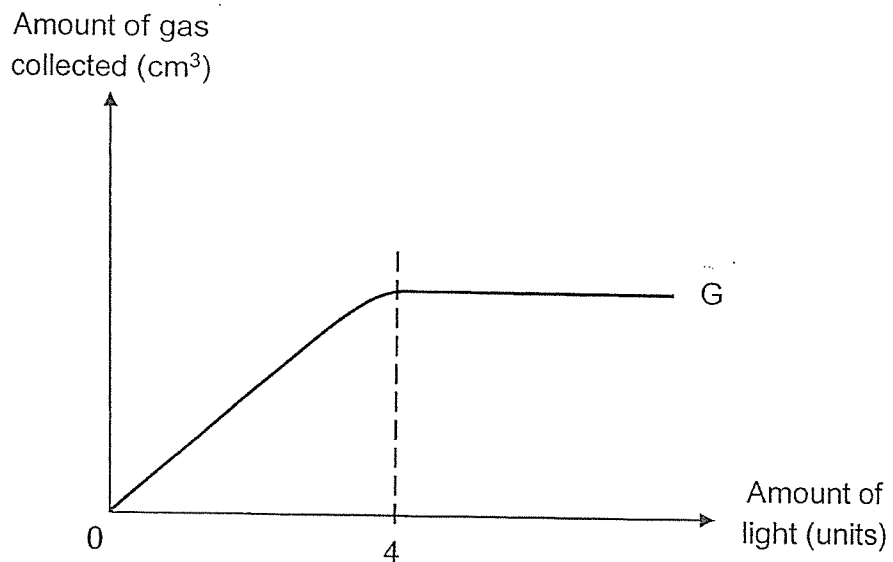

- (a) Based on the graph, what is the relationship between the amount of gas collected in the test tube and the amount of light given to the plant? [2]

Question 37 continues on next page

Rex repeated the experiment by adding substance X, which produces carbon dioxide when dissolved in water, into the beaker.

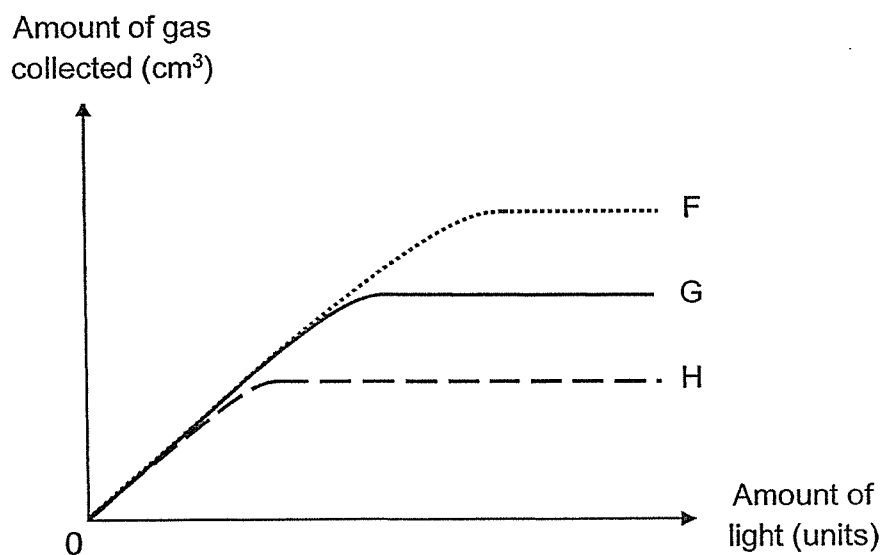







- (b) State which graph, F or H, shows the correct results for the experiment after Rex added substance X. Explain your answer. [1]

- (c) Give a reason why measuring the amount of gas collected is more accurate than counting the number of bubbles produced. [1]

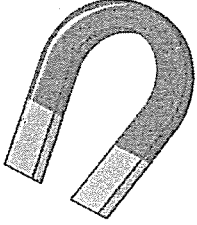
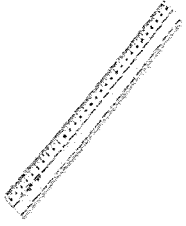
38 Ali wanted to find out how the mass hung on a spring affects the length of the spring.

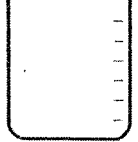
(a) Complete the table below. Tick (✓) the materials to be used in the experiment.

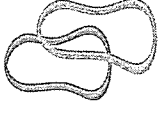
[1]

Materials		Tick (✓)	Materials		Tick (✓)
magnet			ruler		
load hanger			beaker		
retort stand			spring		
rubber band			mass		

Question 38 continues on next page.

39 The table shows the type of gases in the air that are taken in and given out by a human.

Gas	Air taken in (%)	Air given out (%)
nitrogen	78	P
oxygen	21	16%
carbon dioxide	Less than 1	Q
other gases	Less than 1	2

(a) How does the value of P and Q change?

Put a tick (✓) in the correct box.

[1]

	Increase	Decrease	Remain the same
P			
Q			

(b) Give a reason why there is a change in the percentage of oxygen in the air that is taken in and given out.

[1]

Question 39 continues on next page

- (c) Dan carried out some activities where he exercised and then stopped after some time. The graph below shows the changes in Dan's heart rate.

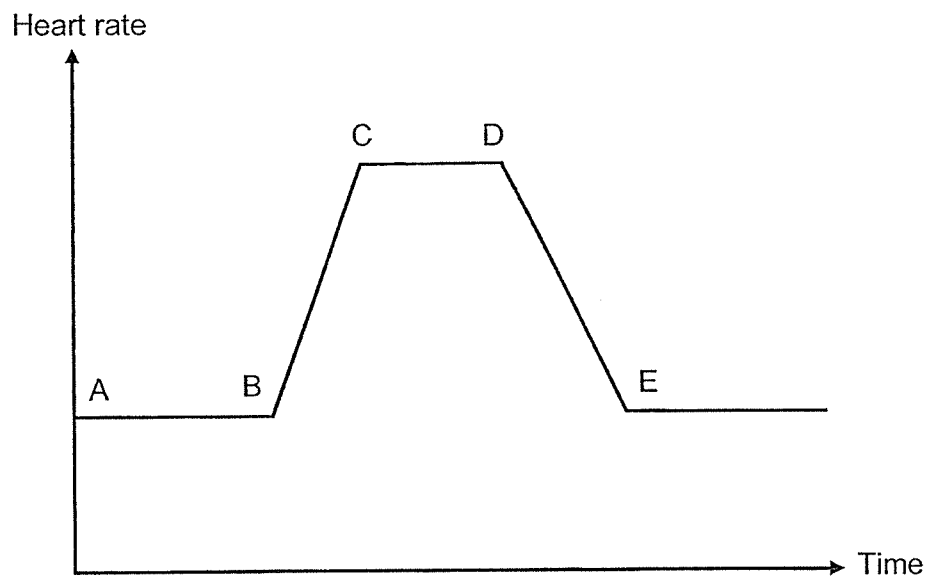

At which points, A, B, C, D or E, show the following: [1]

Start of exercise : _____

End of exercise : _____

- (d) Explain why Dan's heart rate decrease from D to E. [2]

40 (a) State the difference between evaporation and boiling. [1]

(b) Jason left a sealed container of water in an enclosed room with a surrounding temperature of 33°C as shown in the diagram below.

(i) He observed some water droplets forming on the set-up after a few minutes. [1]
On the diagram below, **draw** the water droplets observed by Jason.

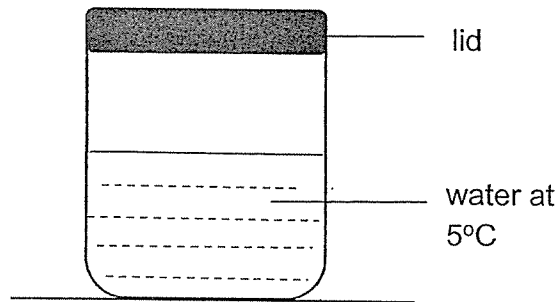

(ii) Explain how the water droplets formed. [1]

- 41 Kenny set up an experiment as shown in the diagram below. He dropped a metal ball from a height of 1m above the ground. The soft toy moved upwards when the metal ball hit the ramp.

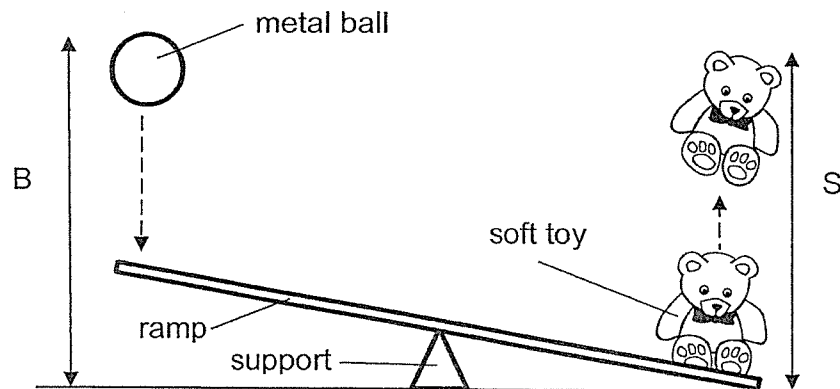

He repeated the experiment by releasing the metal ball at different heights and recorded the height at which the soft toy reached in the table as shown below.

B (m)	S (m)
1	0.6
1.5	0.8
2	1.1

- (a) What should Kenny do to ensure that the results he obtained are reliable? [1]

Kenny heated the metal ball for 10 minutes. He repeated the experiment by releasing the metal ball at the height of 1m.

- (b) **Circle** the correct answer. [1]

The height at which the soft toy reached will be
(lower than / the same as / greater than) the height the soft toy
reached before the metal ball was heated.

- (c) Explain your answer in part (b). [1]

-- END OF PAPER --

SCHOOL : PEIHWAS PRESBYTERIAN PRIMARY SCHOOL
LEVEL : PRIMARY 6
SUBJECT : SCIENCE
TERM : 2021 SA2

SECTION A

Q 1	Q2	Q3	Q4	Q5	Q6	Q7	Q8	Q9	Q10
4	2	4	4	4	2	4	1	1	4
Q 11	Q12	Q13	Q14	Q15	Q16	Q17	Q18	Q19	Q20
1	3	2	2	1	1	3	1	3	3
Q 21	Q22	Q23	Q24	Q25	Q26	Q27	Q28		
3	3	4	4	3	2	2	2		

SECTION B

Q29)	a) Plastic. This is because it is waterproof and can prevent the user from getting wet in the rain. b) It is flexible.
Q30)	a) P: Carbon dioxide Q: Oxygen b) To transport blood from the heart to all parts of the body and back to the heart.
Q31)	a) 4 b) It does not change. This is because the animal X is in pupa stage and it does not eat. c) Butterfly
Q32)	a) B

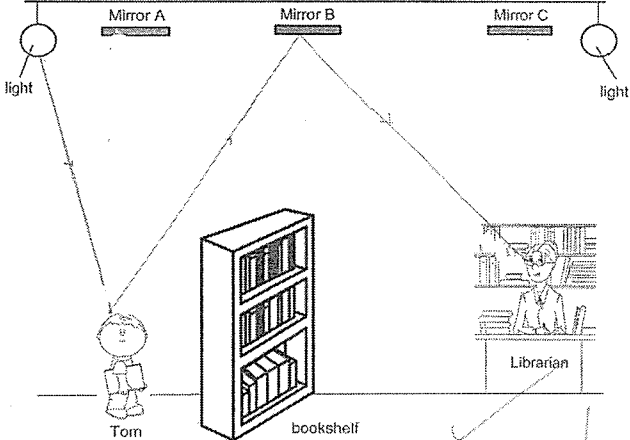
	 <p>b)</p> <p>c) There were other light sources at different angles, creating many shadows.</p>
Q33)	<p>a) Temperature is a measure of the degree of hotness or coldness of an object.</p> <p>b) i) Take measurement at shorter intervals of 5 minutes. ii) Water is a better conductor of heat so animal P will lose heat faster to the water.</p>
Q34)	<p>a) X ; wind : The wing-like structure allows fruit X to stay afloat in the air longer to be dispersed further away. Y ; Explosive action : When the pod is dried up, the pod like structure when split will shoot the seed out of the fruit</p> <p>b) This is so that competition between young plants and the parent plant for sunlight, space, water, and mineral salts can be reduced.</p>
Q35)	<p>a) The aim is to see if the animal R gives out carbon dioxide.</p> <p>b) False True Not possible to tell</p> <p>c) To ensure that the limewater turning chalky is solely due to animal R and not other factors.</p>

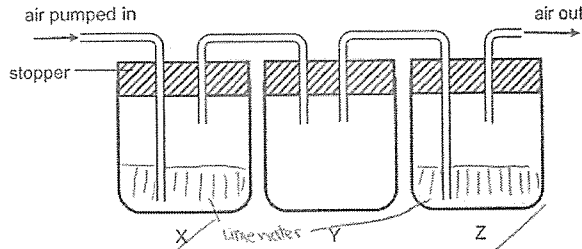
	 <p>d)</p>
Q36)	<p>a) Heat > heat > kinetic > kinetic</p> <p>b) When the temperature of the heater is increased, there is more heat energy from the heater is transferred to more heat energy in the air. More heat energy in the air is converted to more kinetic energy in the air which is transferred to more kinetic energy of the spiral, so the spiral moves fast.</p>
Q37)	<p>a) As the amount of light given to the plant increases from 0 to 4 units, the amount of gas collected in the test tube increased. As the amount of light give in the test tube remains the same.</p> <p>b) F. As plants need carbon dioxide to photosynthesise, with more carbon dioxide dissolved in water by substance X, the plant can photosynthesise at a faster rate, producing more oxygen.</p> <p>c) This is because the bubbles may be of different sizes and contain different amount of air in them.</p>
Q38)	<p>a) Ruler , load hanger, retort stand, spring, mass</p> <p>b) He should measure the length of the spring before attaching one end of the spring to the retort stand. Next , he could put a 10g weight on the load hanger before hanging the load hanger to the other end of the spring. Then, measure the length of the spring and record it down. Lastly, repeat the experiment with weights of 30g and 50g instead.</p> <p>c) Type of spring.</p>
Q39)	<p>a) P : remain the same Q : increase</p> <p>b) Our body takes in oxygen for live processes.</p> <p>c) B D</p>

	<p>d) When Dan stopped exercising, he needed less energy so his body required less oxygen. His heart will pump less oxygenated blood to the rest of the body.</p>
<p>Q40)</p>	<p>a) Evaporation can occur at temperature but boiling only occurs at a fixed temperature.</p> <div data-bbox="555 510 981 772" data-label="Diagram"> </div> <p>b) i) _____ ii) The container lost heat to the water at 5°C</p>
<p>Q41)</p>	<p>a) He should repeat the experiment until he gets at least 3 consistent results.</p> <p>b) The same as</p> <p>c) Since the mass of the metal ball is the same after heating, the gravitational potential energy of the ball is the same. This results in the same kinetic energy transferred to the ramp, so the height at which the soft toy reached will be the same.</p>