



NAN HUA PRIMARY SCHOOL
PRELIMINARY ASSESSMENT – 2021
PRIMARY 6

SCIENCE

BOOKLET A

28 Multiple Choice Questions (56 marks)

Total Time for Booklets A and B: 1 hour 45 minutes

INSTRUCTIONS TO CANDIDATES

1. Write your name and index number in the space provided.
2. Do not turn over the page until you are told to do so.
3. Follow all instructions carefully.
4. Answer all questions.
5. Shade your answers in the Optical Answer Sheet (OAS) provided.

Marks Obtained

Booklet A		/ 56
Booklet B		/ 44
Total		/ 100

Name: _____ () Class: P 6 _____

Date : 24 August 2021

Parent's Signature: _____

Section A: (28 × 2 marks = 56 marks)

For each question from 1 to 28, four options are given. One of them is the correct answer. Make your choice (1, 2, 3 or 4) and shade your answer on the Optical Answer Sheet.

1 Study the classification chart and the three animals P, Q and R.

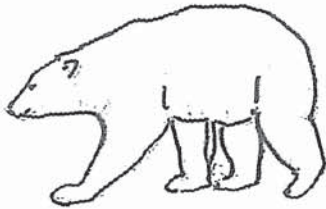

P



Q



R

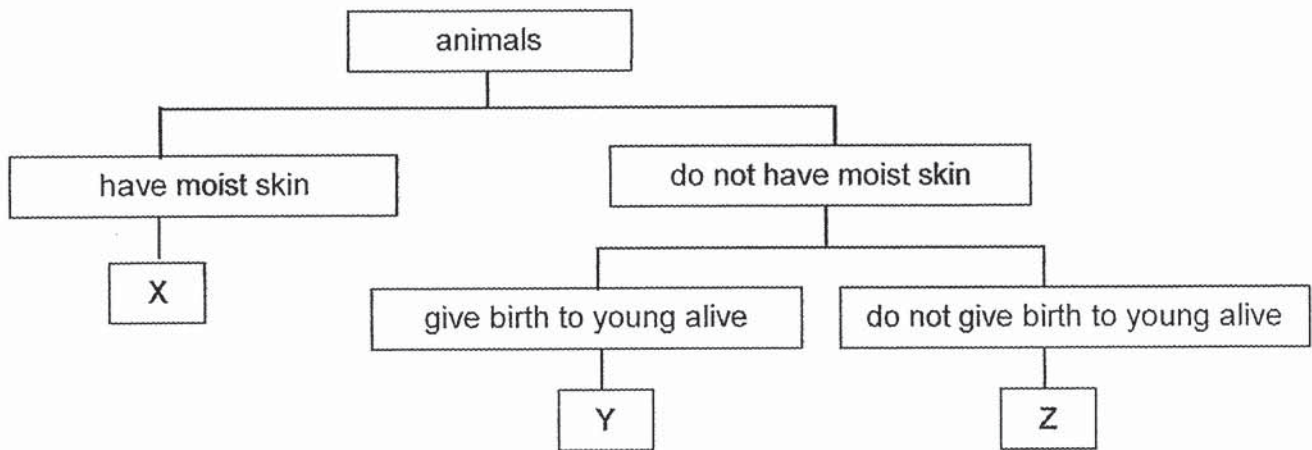

Which of the following shows the correct classification of animals in boxes X, Y and Z?

	X	Y	Z
(1)	P	Q	R
(2)	Q	R	P
(3)	R	P	Q
(4)	R	Q	P

2 The diagram below shows the life cycles of two animals.

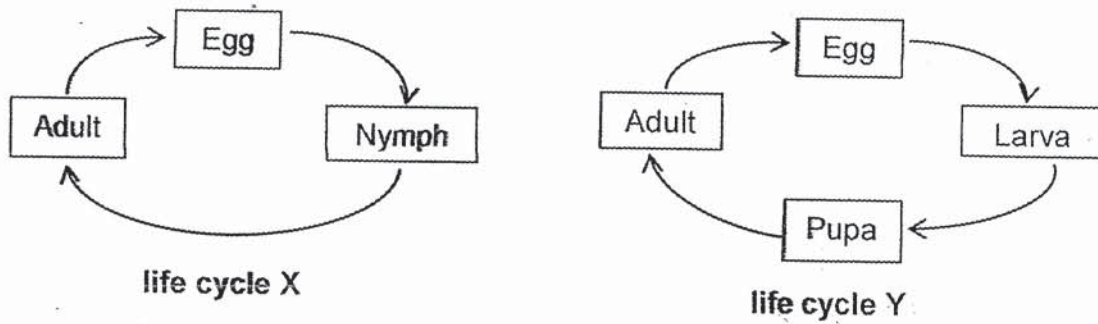

Which animals are likely to have the life cycles as shown above?

	life cycle X	life cycle Y
(1)	frog	beetle
(2)	chicken	mosquito
(3)	butterfly	cockroach
(4)	grasshopper	butterfly

3 The plant in the diagram below is surrounded by weeds.

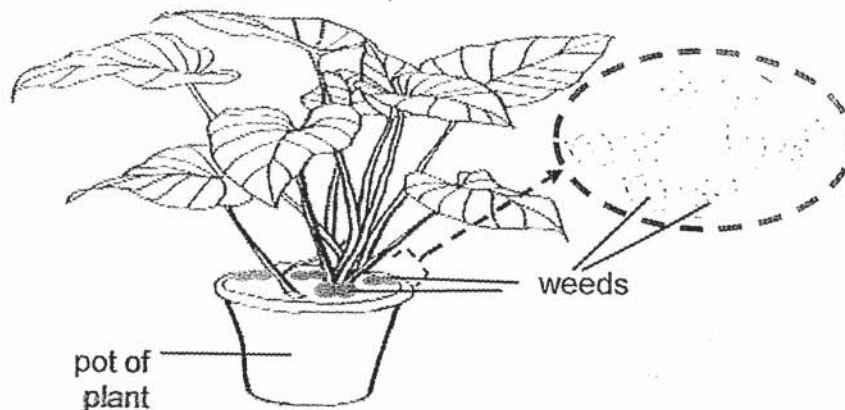

Based on the diagram above, which of the following does the plant need to compete with the weeds for?

- A space
 - B water
 - C sunlight
 - D mineral salts
- (1) B and C only
 (2) C and D only
 (3) A, B and D only
 (4) A, B, C and D

- 4 Meiling wanted to grow some mushrooms at home. She sprinkled equal masses of mushroom spores into four bags of sawdust and placed the bags in boxes A, B, C and D as shown below.

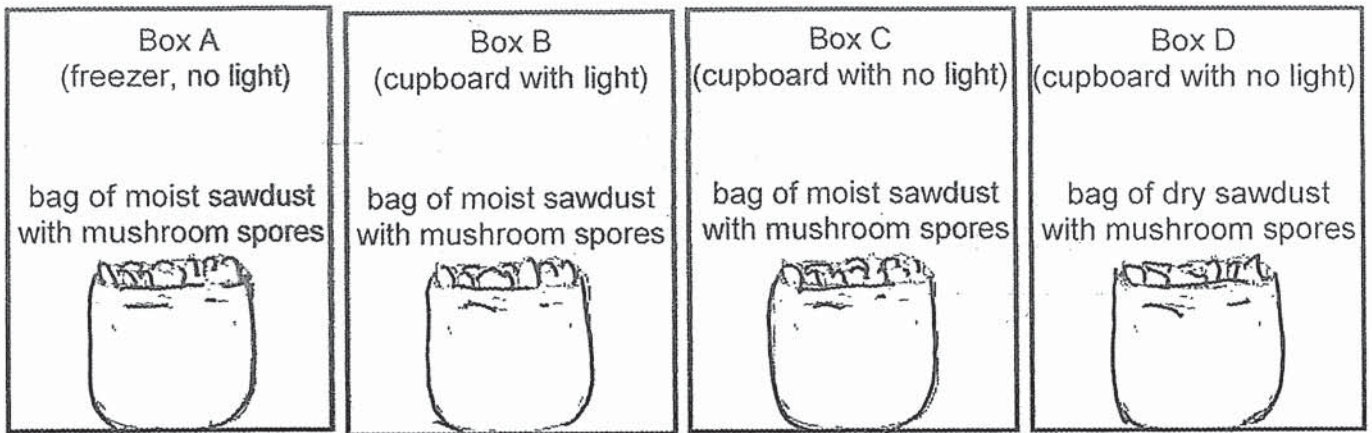

Below are the results of her growing mushroom project after two weeks.

Box	Mushroom observed after two weeks
A	No
B	Yes
C	Yes
D	No

From the set-ups and results provided, which statement can Meiling conclude from this experiment?

- (1) Spores require only water for germination.
- (2) Spores require only warmth for germination.
- (3) Spores require water and warmth for germination.
- (4) Spores require water, warmth and light for germination.

- 5 The diagrams below show the male and female reproductive systems of humans and a plant.

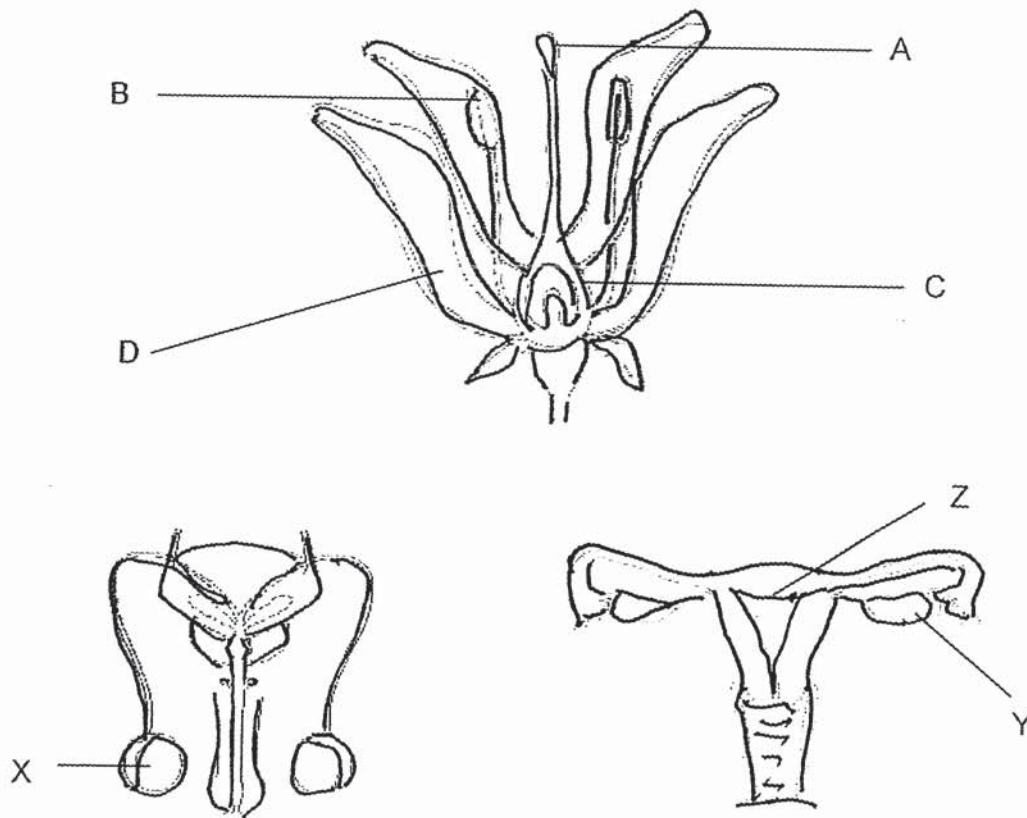

Which of the following parts are correctly matched to their functions?

	Contain male reproductive cells	Contain female reproductive cells	Place where developing baby develops
(1)	A and X	A and Y	B and Y
(2)	B and X	C and Y	C and Z
(3)	C and X	B and Y	D and Z
(4)	D and X	A and Y	A and Z

6 The diagram below shows a male reproductive cell in humans.

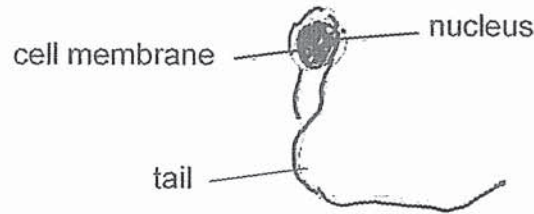

Which of the following statements about the male reproductive cell is/are correct?

- A Its tail helps it to move.
- B Its nucleus contains all the characteristics from the mother which is to be inherited by the baby.
- C For fertilisation to occur, the male reproductive cell needs to fuse with the female reproductive cell.

- (1) A only
- (2) A and B
- (3) A and C
- (4) A, B and C

7 The diagrams below shows plant Q growing in the pond.

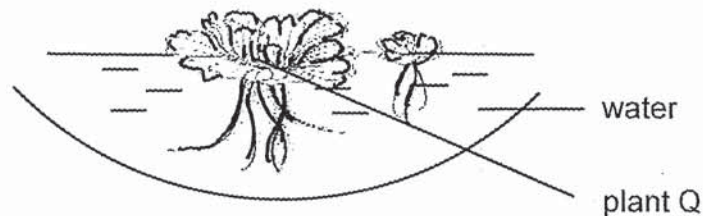

What of the following is/are the function(s) of the roots of plant Q?

- A To take in water and dissolved mineral salts
- B To hold the plant firmly to the soil
- C To store food

- (1) A only
- (2) A and B
- (3) A and C
- (4) B and C

8 The diagram below shows the digestive system of a human

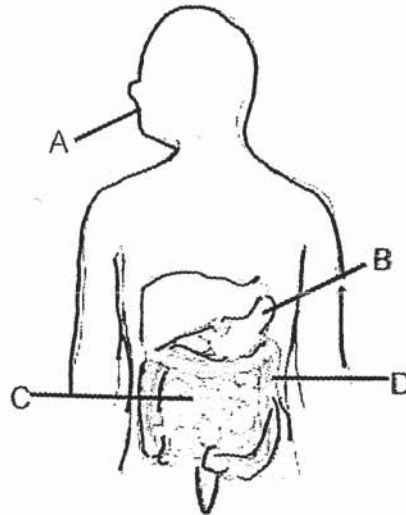

Which of the organs A, B, C and/or D is/are involved in both the digestion and absorption of food?

- (1) C only
- (2) A and C only
- (3) C and D only
- (4) B, C and D only

9 Which of the organs of the respiratory system is/are correctly matched to its/ their function(s)?

Organ	Function
nose	breathe in and out air
windpipe	connects the nose to the lungs
lungs	oxygen from the bloodstream enters the lungs to exchange for carbon dioxide

- (1) nose only
- (2) nose and windpipe only
- (3) windpipe and lungs only
- (4) nose, windpipe and lungs

- 10 David drew the diagram below to show the direction of blood flow in some parts of the human body.

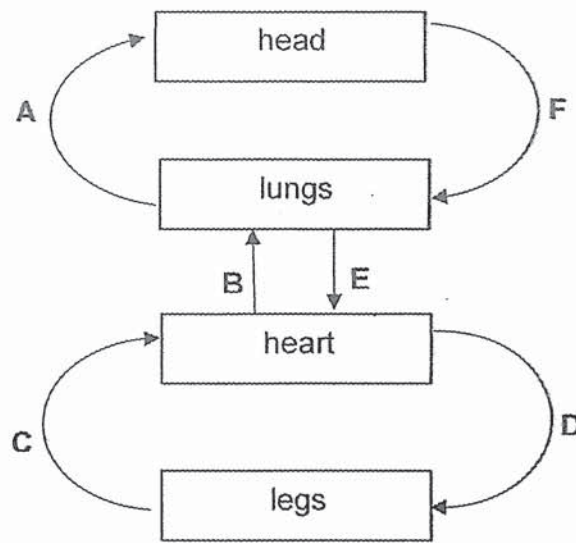

Which two arrows were **not** drawn correctly?

- (1) A and B
 - (2) A and F
 - (3) C and D
 - (4) E and F
- 11 Three types of cells P, Q and R are shown.

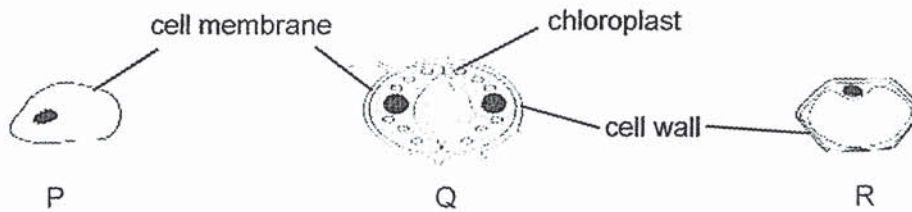

Which of the following gives the correct classification of the plant cells and its explanation?

	Plant cell	Explanation
(1)	Q only	It has chloroplasts.
(2)	P and Q only	Only P and Q have regular shapes.
(3)	Q and R only	Only Q and R have cell wall.
(4)	P, Q and R	All three cells have a nucleus.

- 12 Ryan kept a potted plant in a dark room for 24 hours. He then set up an experiment as shown below. He wrapped three similar size leaves in different types of plastic bags of identical sizes and placed the plant under bright light.

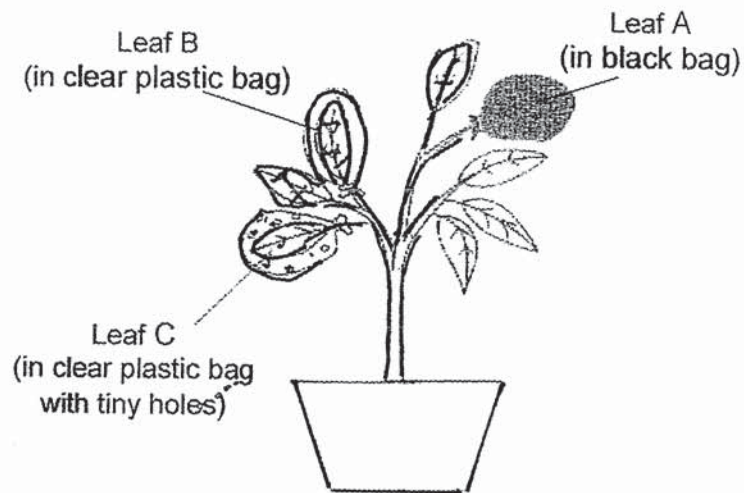

After several hours, the leaves A, B and C were plucked and tested for food. Which leaf/ leaves is/are food likely to be found in?

- (1) A only
- (2) B only
- (3) B and C only
- (4) A, B and C

- 13 Plant A and plant B are grown in two different locations. The graph below shows the amount of oxygen produced by the two plants over a 24-hour period.

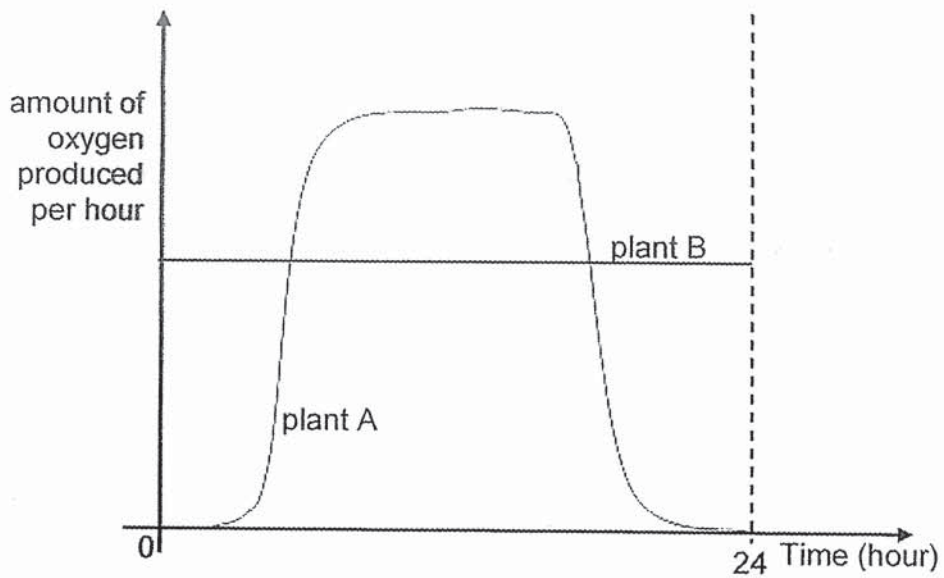

Based on the graph above, which of the following statements is/are correct?

- A Plant A is larger than plant B.
 - B Plant B is provided with a constant supply of light while Plant A is not.
 - C Both plants have made food throughout the 24-hour period.
-
- (1) A only
 - (2) B only
 - (3) B and C
 - (4) A, B and D only

14 Study the flow chart below.

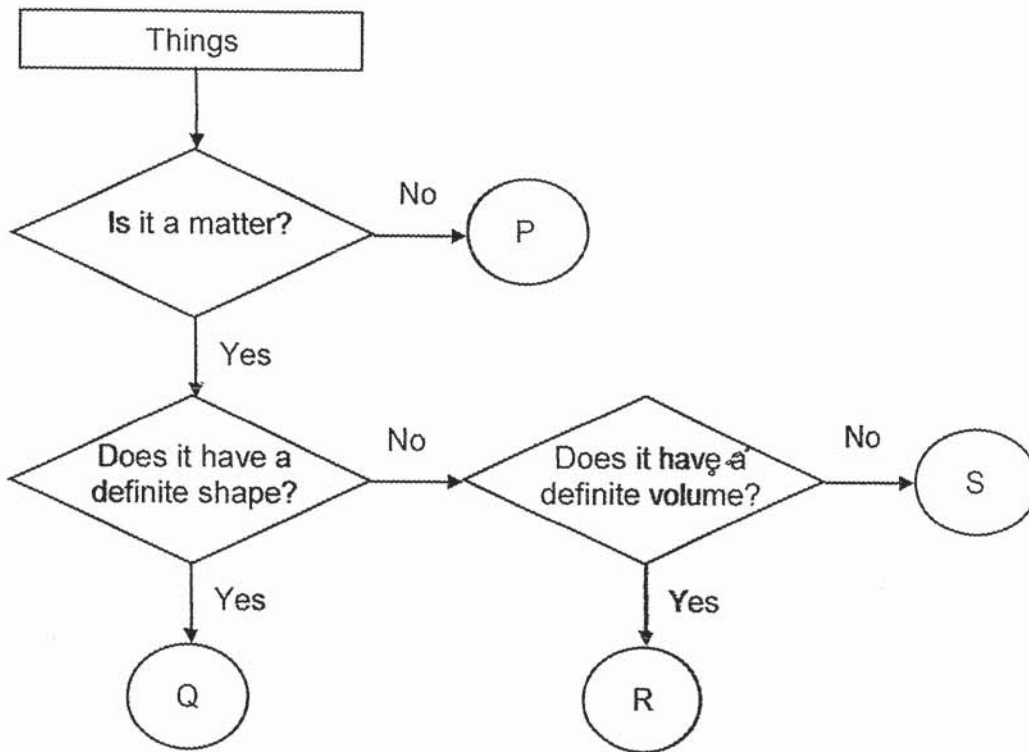

Which one of the following represents steam in the flow chart?

- (1) P
- (2) Q
- (3) R
- (4) S

15 The table below shows the melting points and boiling points of substances W, X, Y and Z.

Substance	Melting point (°C)	Boiling point (°C)
W	34	55
X	32	85
Y	21	180
Z	9	31

Which of the substances will be liquid at 33 °C?

- (1) W only
- (2) W and Z only
- (3) X and Y only
- (4) X, Y and Z only

16 Study the diagram below.

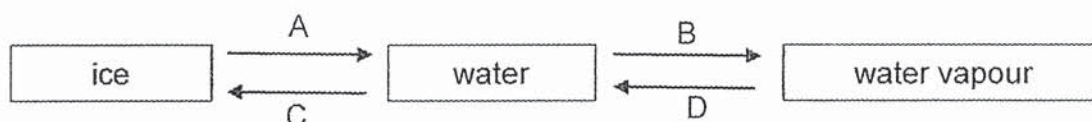

In which of the processes, A, B, C or D, will the substance gain heat as it changes from one state to another?

- (1) B only
- (2) A and B only
- (3) A and D only
- (4) B, C and D only

17 Sara hung objects Q, R and S in between a torch and a screen as shown below.

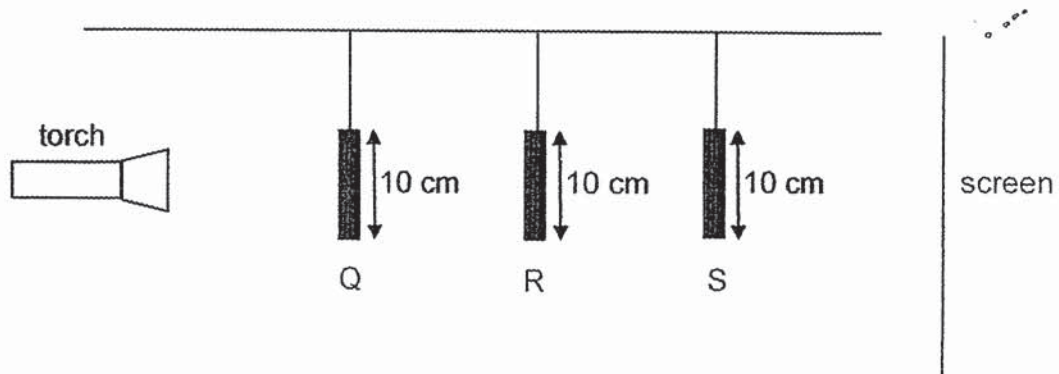
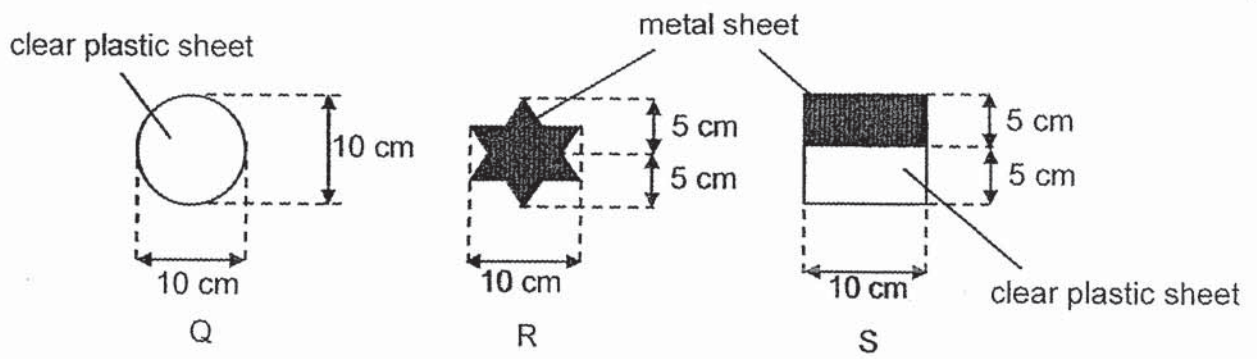

Which of the following shows the shadow formed on the screen when the torch was turned on?

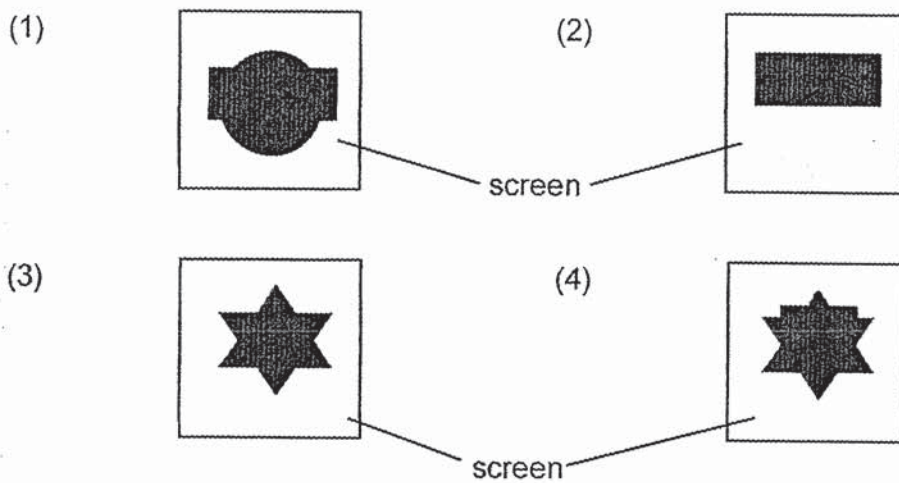

- 18 The diagram below shows two glasses, A and B, stuck together.

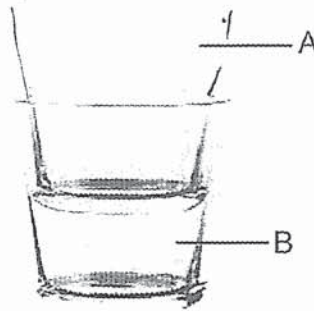

What should Alex do to separate glasses A and B?

- (1) He should place glass B in a basin of iced water.
 - (2) He should place both glasses into a basin of hot water.
 - (3) He should pour iced water into glass A and place glass B in a basin of hot water.
 - (4) He should pour hot water into glass A and place glass B in a basin of iced water.
- 19 Which of the following correctly shows the energy conversion that took place when a television set is switched on?
- (1) Light energy \rightarrow heat energy + sound energy
 - (2) Electrical energy \rightarrow light energy + heat energy + sound energy
 - (3) Chemical potential energy \rightarrow light energy \rightarrow heat energy + sound energy
 - (4) Electrical energy \rightarrow Chemical potential energy \rightarrow light energy + sound energy + heat energy

20 The diagram below shows a tower in an adventure camp.

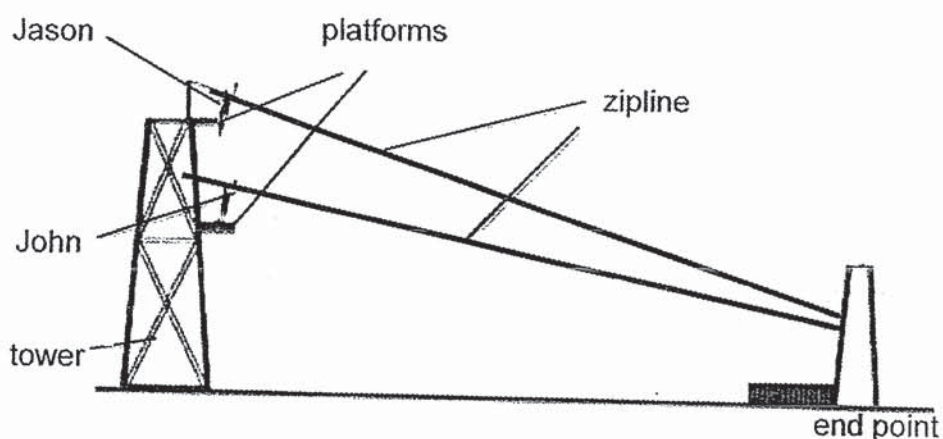

Jason and John have the same mass. Which of the following statements best describes the gravitational potential energy possessed by Jason and John when they are on the platforms?

- (1) Both of them have no gravitational potential energy.
- (2) Jason has more gravitational potential energy than John.
- (3) Jason has less gravitational potential energy than John.
- (4) Both of them have the same gravitational potential energy.

21 The diagram below shows how four bulbs are connected to two batteries in a circuit.

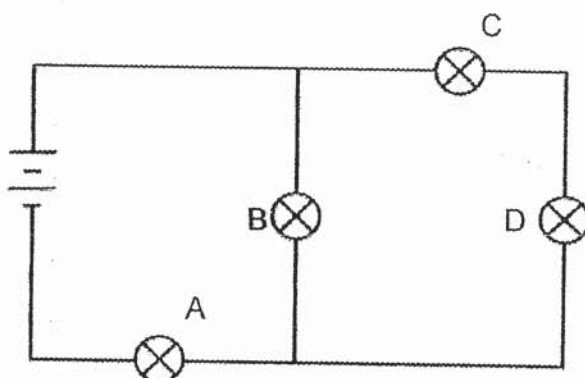

After one of the bulbs had blown, the other three bulbs remained lit. Which bulb had blown?

- (1) A
- (2) B
- (3) C
- (4) D

22 Study the circuits below.

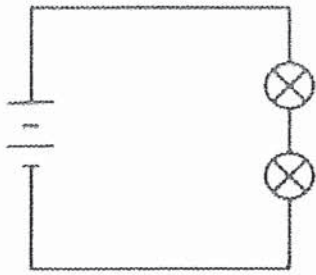

circuit A

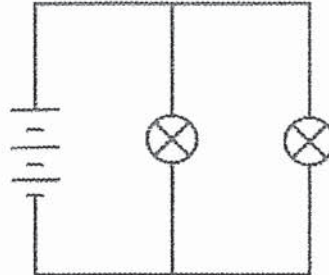

circuit B

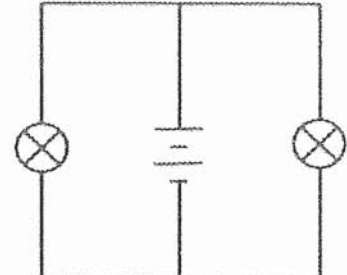

circuit C

Arrange the circuits in order from the brightest bulbs to the dimmest.

- (1) A, B, C
- (2) B, C, A
- (3) C, A, B
- (4) C, B, A

23 Which of the following shows the correct properties of a mirror?

	Does it give out its own light?	Does it allow light to pass through?
(1)	No	No
(2)	No	Yes
(3)	Yes	No
(4)	Yes	Yes

- 24 The diagram below shows a watch used by divers when they dive into the sea.

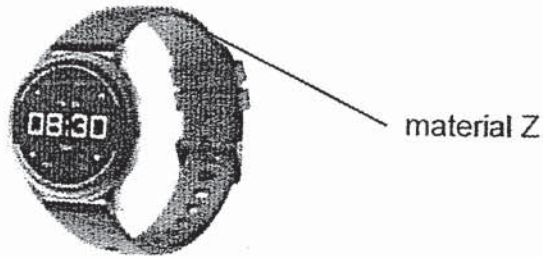

Which of the following properties are important when choosing material Z for making the strap of the diver's watch?

- A Flexibility
- B Waterproof
- C Float in water
- D Allows light to pass through

- (1) A and B only
- (2) B and C only
- (3) A, C and D only
- (4) A, B, C and D

- 25 Mina was given three rods, W, X and Y, as shown below.

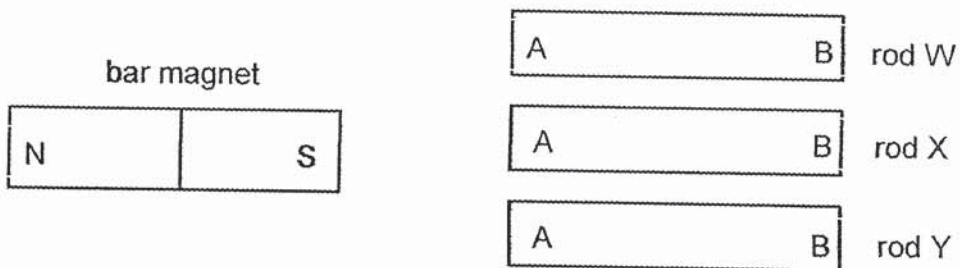

She brought the bar magnet closer to each rod and recorded her observations in the table as shown below.

Rod	Observations
W	A and B are attracted by the north pole of the magnet.
X	A is repelled by the south pole of the magnet.
Y	It remained at the same position.

Which of the following is a possible conclusion based on the results of the experiment above?

- (1) Rod X is a magnet.
- (2) Rods W and X are magnets.
- (3) Rod X and Y are magnetic materials.
- (4) Rod Y can be made into an electromagnet.

26 The diagram below shows a boy flying a kite.

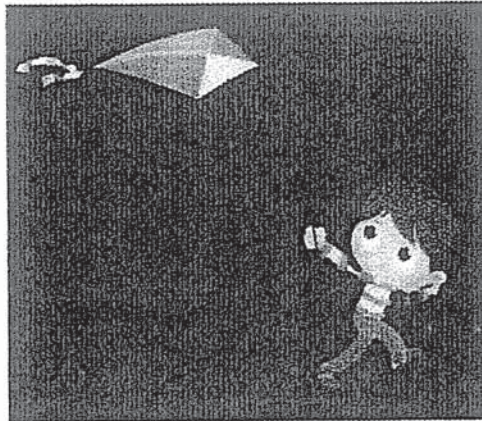

What are the forces acting on the flying kite which is attached to a cotton string?

- A Air resistance
- B Magnetic force
- C Gravitational force
- D Elastic spring force

- (1) A and B only
- (2) A and C only
- (3) C and D only
- (4) B, C and D only

- 27 Cindy hung three identical springs from the ceiling as shown below. Each spring was attached to an object of equal mass.

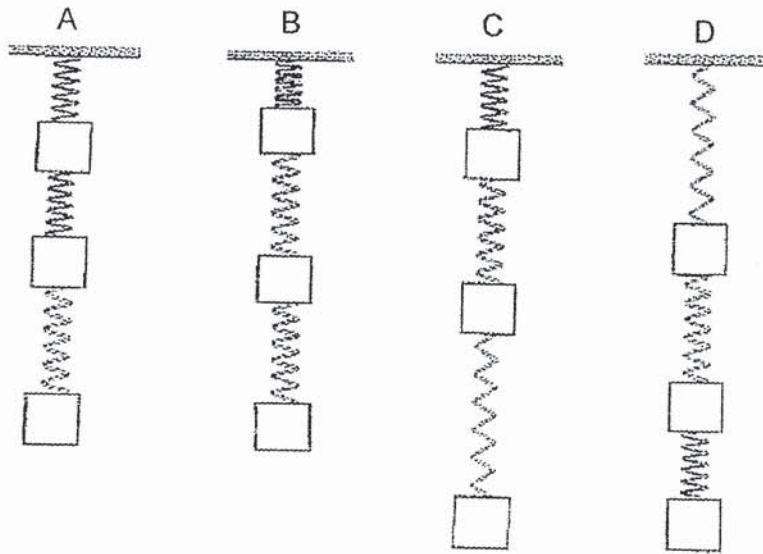

Which of the following is a possible observation Cindy would make?

- (1) A
- (2) B
- (3) C
- (4) D

- 28 Four balls of different materials, A, B, C and D, were suspended on 4 identical strings of two different lengths. The four strings were cut at the dotted line and the balls dropped into the sandbox as shown in the set-up below.

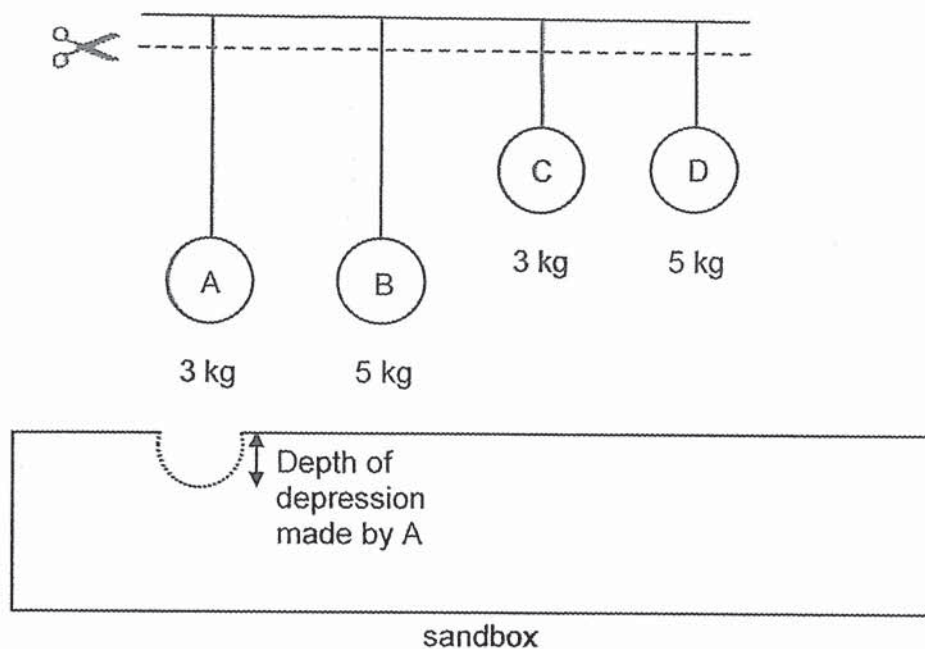

The depressions made by the balls were measured and recorded in the table below.

Ball	Depth of depression in sand (cm)
A	0.8
B	2.5
C	3
D	5

Based on the set-up above, which of the following statement(s) is/are correct?

- A More gravitational force is acting on ball C than ball A.
 - B Ball D has more gravitational potential energy than ball B.
 - C Ball D makes a deeper depression than ball C because it has more mass.
- (1) A and B only
- (2) A and C only
- (3) B and C only
- (4) A, B and C

End of paper



NAN HUA PRIMARY SCHOOL
PRELIMINARY ASSESSMENT – 2021
PRIMARY 6

SCIENCE

BOOKLET B

13 Structured / Open-ended questions (44 marks)

Total Time for Booklets A and B: 1 hour 45 minutes

INSTRUCTIONS TO CANDIDATES

1. Write your name and index number in the space provided.
2. Do not turn over the page until you are told to do so.
3. Follow all instructions carefully.
4. Answer all questions.
5. Write your answers in this booklet.

Marks Obtained

Section B

	/ 44
--	------

Name: _____ () Class: P 6 _____

Date : 24 August 2021 Parent's Signature: _____

Section B:

For questions 29 to 41, write your answers in the spaces provided.

The number of marks available is shown in brackets [] at the end of each question or part question.

(44 marks)

29 The classification table below shows how some organisms are grouped.

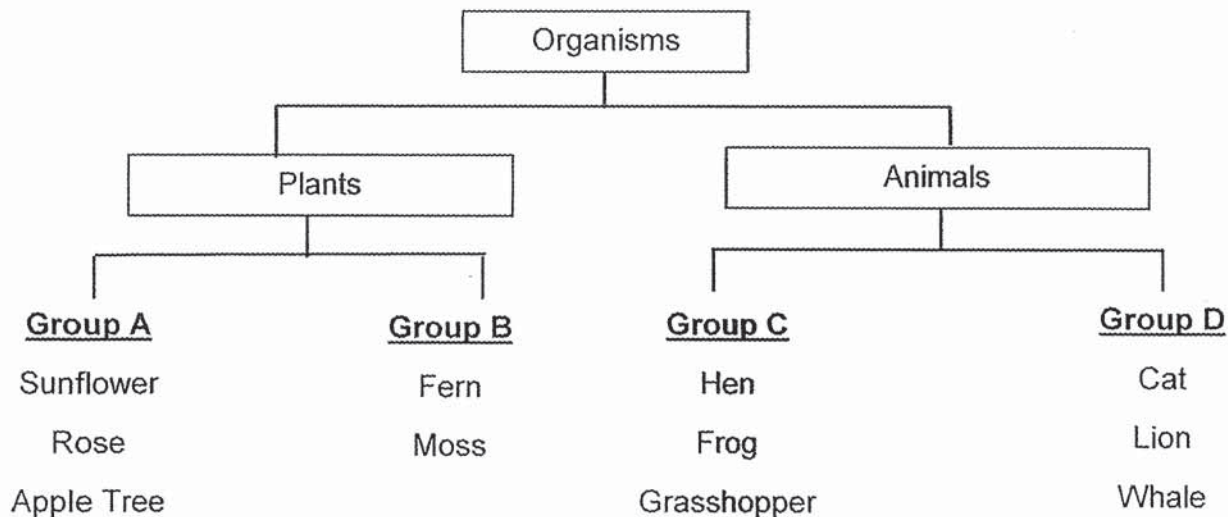

(a) What characteristic is used to group the organisms into groups C and D? [1]

(b) Suggest a difference between the plants in group A and in group B. [1]

Score	2
-------	---

30 Bees are commonly found near flowering plant C.

(a) Describe how the bees help flowering plant C reproduce.

[1]

(b) Ali found many fruits of plant C on the river bank. It has a tough fibrous husk as shown below.

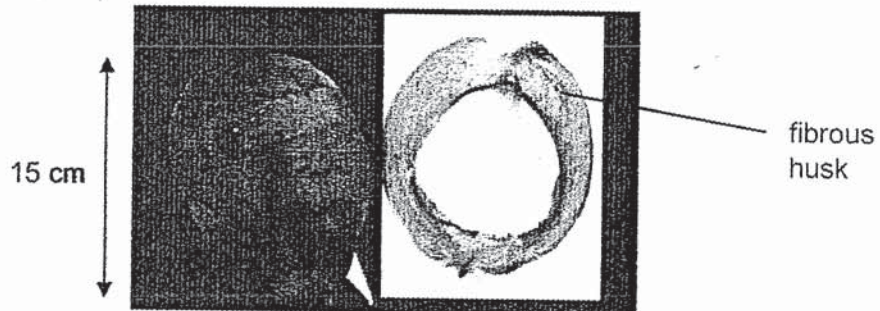

(i) Explain how the characteristic of fruit C shown in the diagram helps in its dispersal. [1]

(ii) The young plants of C grows far apart from one another to prevent overcrowding. Explain why this benefits the plants. [1]

Score	3
-------	---

31 The diagram below shows a human arm.

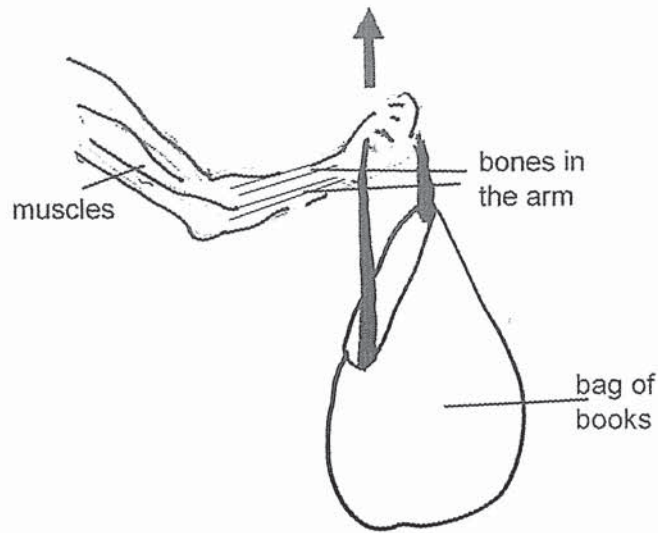

(a) Based on the diagram above, which two systems are needed to work together to lift the bag of books? [1]

(i) System 1 : _____

(ii) System 2: _____

(b) Explain how the circulatory system helps the muscles to lift the bag of books. [2]

Score	3
-------	---

- 32 Jane wanted to find out how the number of leaves in a plant affect how much water is taken in by the plant. She filled up three identical beakers with 1000 ml of tap water each and placed them on a table in the same classroom. Same type of plants of the same height were placed in set-ups A and C.

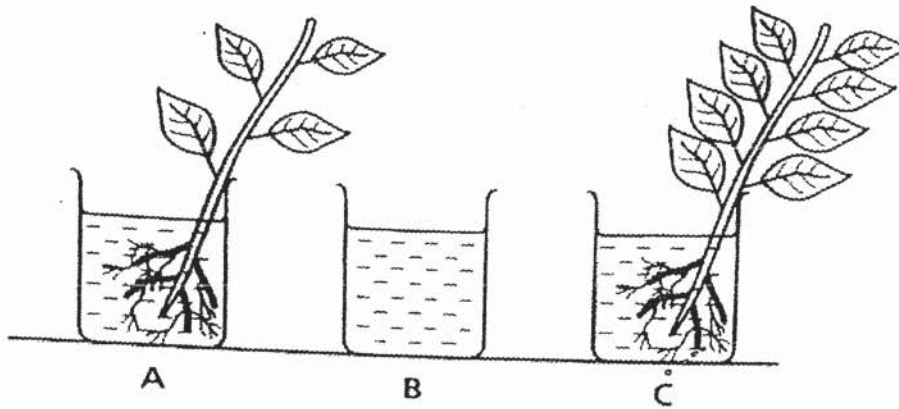

She recorded the amount of water in the beaker at the start and end of the experiment.

	A	B	C
Volume of water at the start of the experiment (ml)	1000	1000	1000
Volume of water at the end of the experiment (ml)	800	900	600

- (a) State one other variable she needed to keep constant for the experiment. [1]

Jane plotted a graph to show the amount of water absorbed by the two plants.

Volume of water absorbed by the plant (ml)

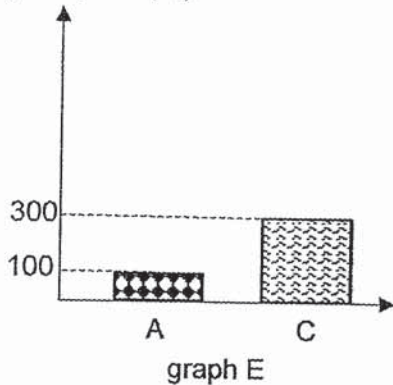

Volume of water absorbed by the plant (ml)

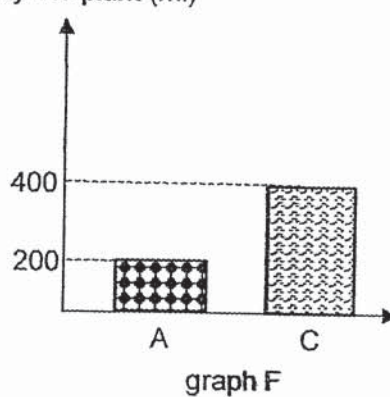

Volume of water absorbed by the plant (ml)

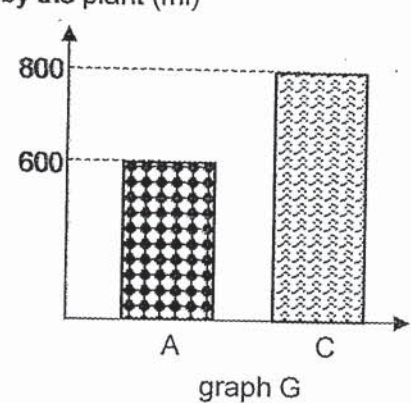

- (b) Based on the information shown in the table on page 5, which graph, E, F or G, correctly represents the volume of water absorbed by the plants in set-ups A and C? [1]

- (c) Show how Jane obtained the volume of water absorbed by the plant in set-up C. [1]

- (d) Explain the purpose of set-up B. [1]

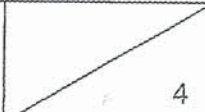
Score	
-------	---

- 33 A family of four were trapped inside a spoiled lift. The graph below shows the amount of oxygen in the lift as time passes.

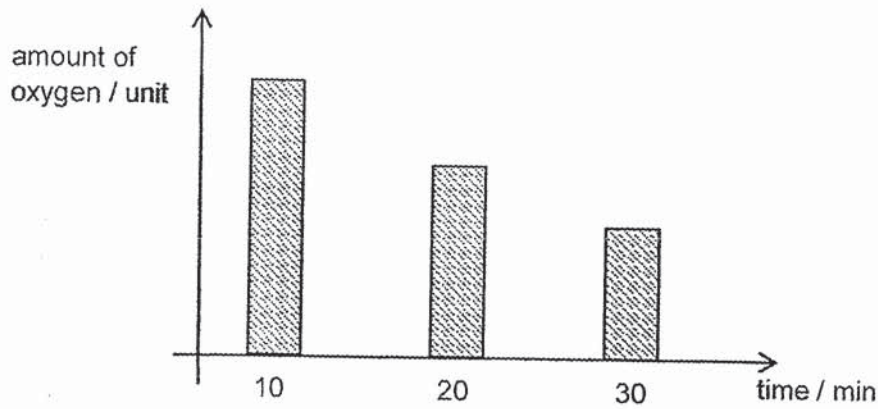

- (a) Explain the change in the amount of oxygen over 30 minutes.

[1]

- (b) After 15 minutes, the two children in the family started jumping and kicking the lift door. Explain how their actions will cause the amount of oxygen in the lift to decrease faster.

[1]

Score	2
-------	---

34 David wanted to find out if the presence of substance Q would affect the rate of photosynthesis of the water plants. He prepared the two set-ups with identical water plants as shown below and placed them under a bright lamp. He counted the number of bubbles produced by the plants.

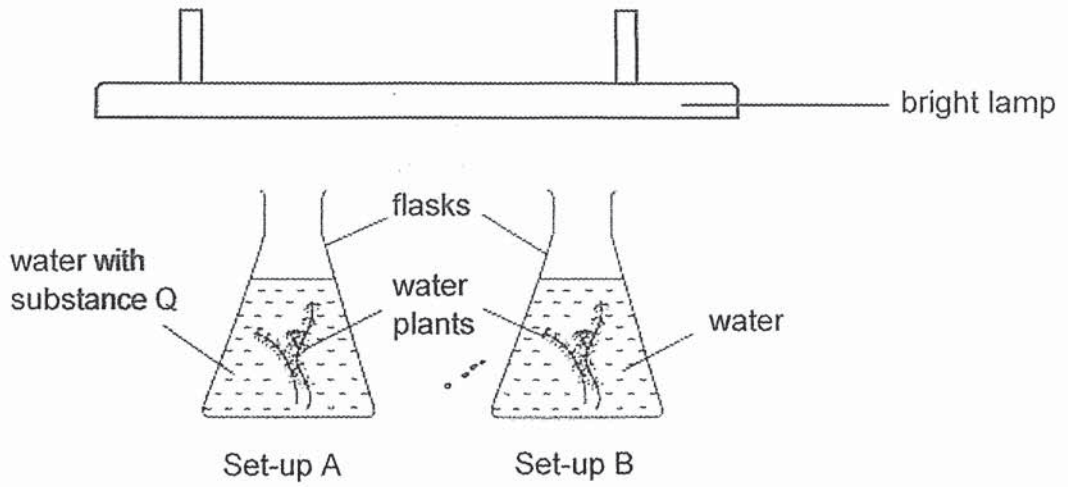

(a) What is photosynthesis? [1]

(b) What observation could lead David to conclude that substance Q increases the rate of photosynthesis of the water plants? [1]

(c) Suggest two changes that David can make to set-up A if he wants to find out if light is needed for photosynthesis. [1]

Score	3
-------	---

35 Kelly filled a container with 150 cm^3 of stones as shown below.

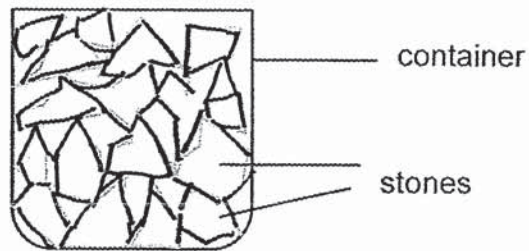

(a) Identify the states of matter found in the above container. [1]

(b) Tick (✓) the box that shows the volume of the container. [1]

Volume of container	Tick (✓) the correct volume of container
Below 150 cm^3	
Exactly 150 cm^3	
Above 150 cm^3	

(c) Explain your answer in (b). [1]

- (d) Kelly wanted to measure the volume of a single stone. She was given a measuring cylinder with some water in it.

Arrange the following procedures in the correct order by writing 1, 2, 3 and 4 in the boxes to show the correct sequence. [1]

Procedure	Step
Calculate the difference in the volume of water.	
Put the stone into the measuring cylinder filled with water.	
Record the initial reading of the water level in the measuring cylinder.	
Record the final reading of the water level in the measuring cylinder.	

Score	4
-------	---

36 The set-up below is used to obtain pure water from seawater.

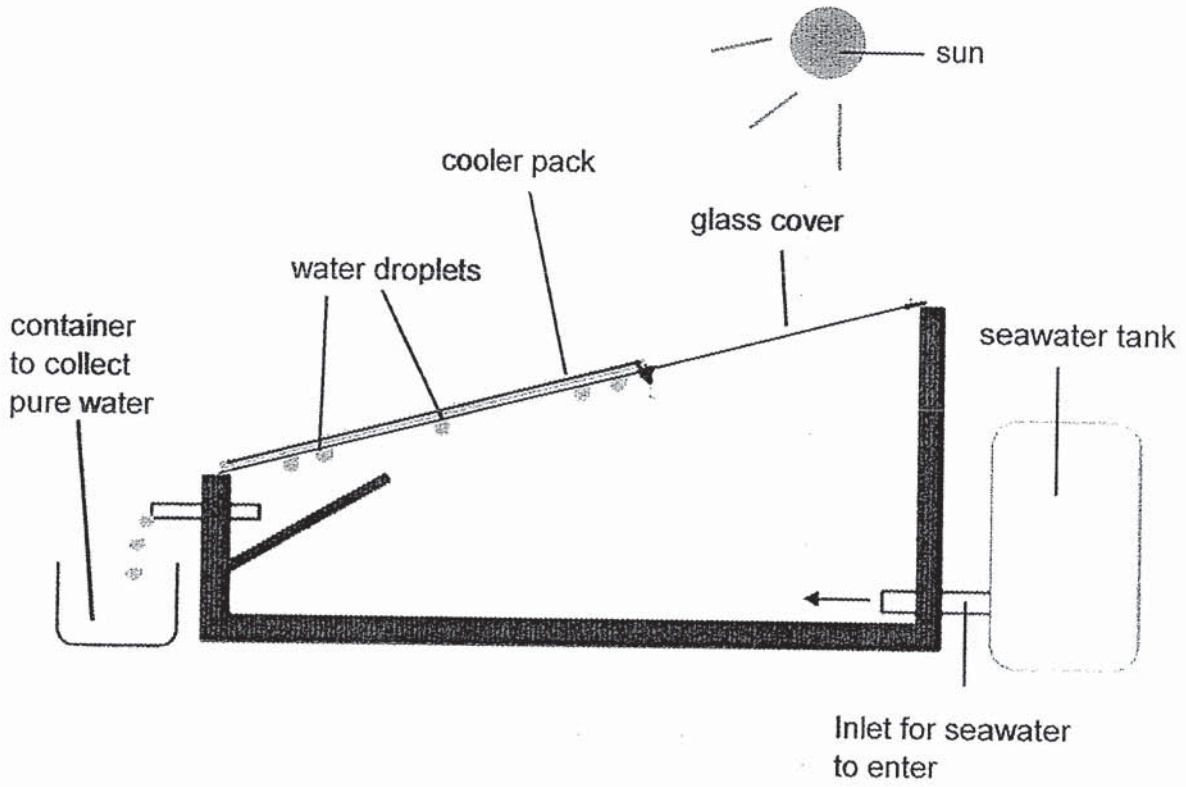

(a) Based on the set-up above, explain how pure water is collected. [2]

The volume of water collected at different times of the day was recorded in the table as shown below.

Time	Volume of water collected (cm ³)
8 am	32
12 pm	93
5 pm	39

(b) Explain why the volume of water collected is the highest at 12 pm.

[1]

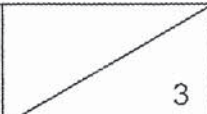
Score	
-------	---

- 37 The diagram below shows two beakers, A and B, each containing 200 cm³ of water and placed in a room with a temperature of 28 °C.

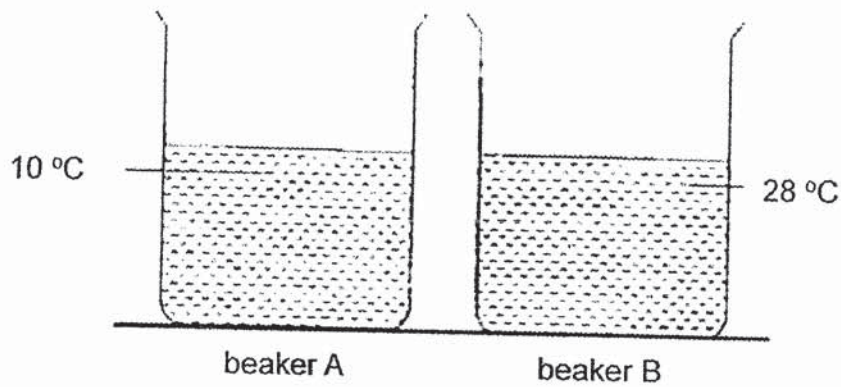

David poured 100 cm³ of water from one of the above beakers to the other. He measured the temperature of the water in both beakers and recorded his readings in the table below.

Time (minutes)	Temperature of water (°C)	
	Beaker A	Beaker B
0	10	20
5	14	22
10	18	23
15	21	24
20	25	26
25	26	27
30	28	28
60	28	?

- (a) Which beaker did David pour the 100 cm³ of water into? [1]

- (b) What would most likely be the temperature of water in beaker B at the 60th minute? [1]

- (c) In terms of heat transfer, explain the change in temperature for the water in beaker A for the duration of the experiment. [1]

- (d) What can David do to cool the water in beaker B quickly without removing it from the table? [1]

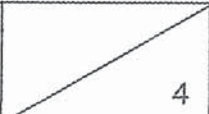
Score	
-------	---

In another experiment, the skater used another ramp that ends at point D as shown below.

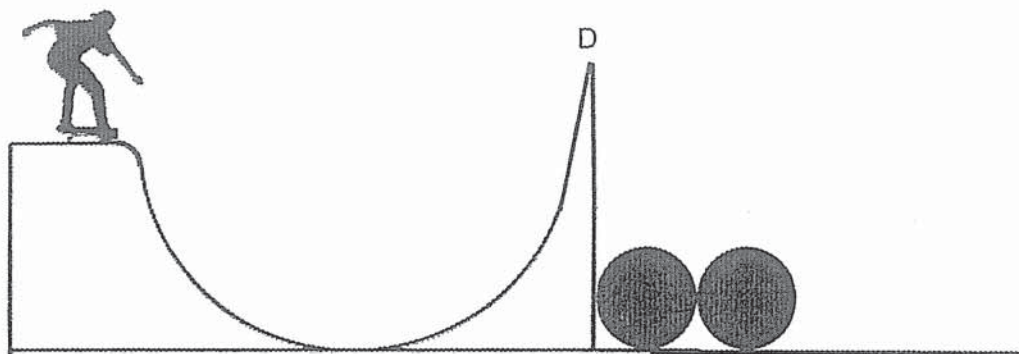

- (c) Explain, in terms of energy conversion, why the skater did not succeed in jumping over the two barrels. [2]

Score	4
-------	---

- 39 Kumar connected six identical bulbs, B1, B2, B3, B4, B5 and B6, to two batteries in the circuit as shown below.

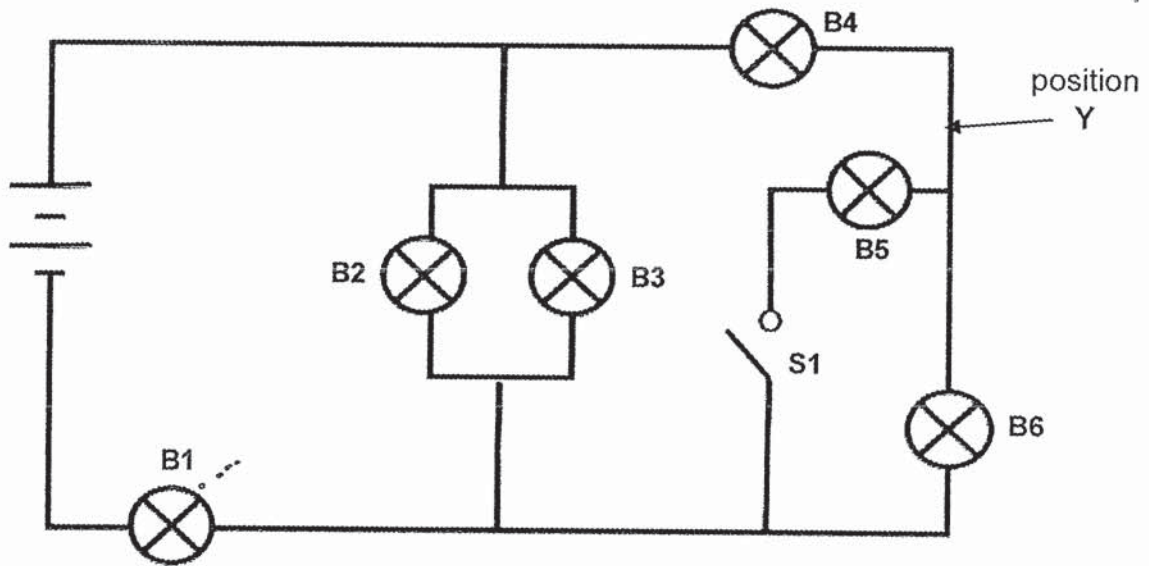

In addition to switch, S1, in the circuit above, Kumar wanted to add another two switches, S2 and S3, to the circuit so that only certain bulbs would light up when different switches were closed according to the table below.

Switch(es) closed	Bulbs that will light up
S1, S2, S3	All bulbs
S2 only	B1, B2 and B3 only
S1 only	B1, B4 and B5 only
S3 only	B1, B4 and B6 only

- (a) Mark the positions of the two additional switches in the circuit above using 'X' and label them as S2 and S3. [2]
- (b) Kumar added another bulb at position 'Y'. When only S1 was closed, would B1, B4 and B5 be brighter, dimmer or remain the same? Explain your answer. [2]

40 A milk company has changed the design of its cans, from design A to design B, as shown below. Both cans contain the same volume of milk.

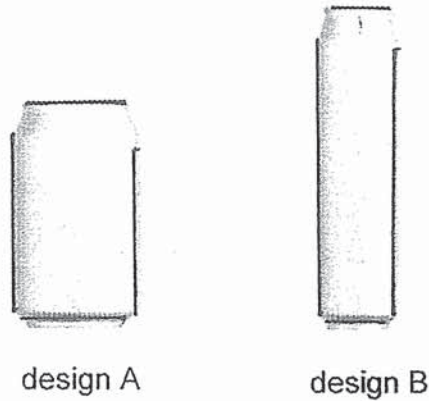

(a) What is the property of liquids that allows the same volume of milk to be filled in both cans? [1]

(b) Some details of the two designs are shown in the table below.

	Design A	Design B
Height	12.2 cm	14.6 cm
Metal Type	aluminum	aluminum
Thickness of metal used	0.012 cm	0.012 cm
Amount of metal used	145.6 cm ²	173.2 cm ²

Two unopened cans of milk, one of design A and the other of design B, are placed into a refrigerator at the same time. After five minutes, the temperature of the milk in both cans are measured.

The temperature of the milk in the can with design B was found to be lower than the temperature of the milk in the can with design A. Explain why. [2]

Score	3
-------	---

41 Max magnetised 3 identical iron bars, A, B and C, using the stroke method. Each iron bar was given a different number of strokes with a magnet. The diagram below shows the maximum distance at which the iron bars would attract the steel paper clips.

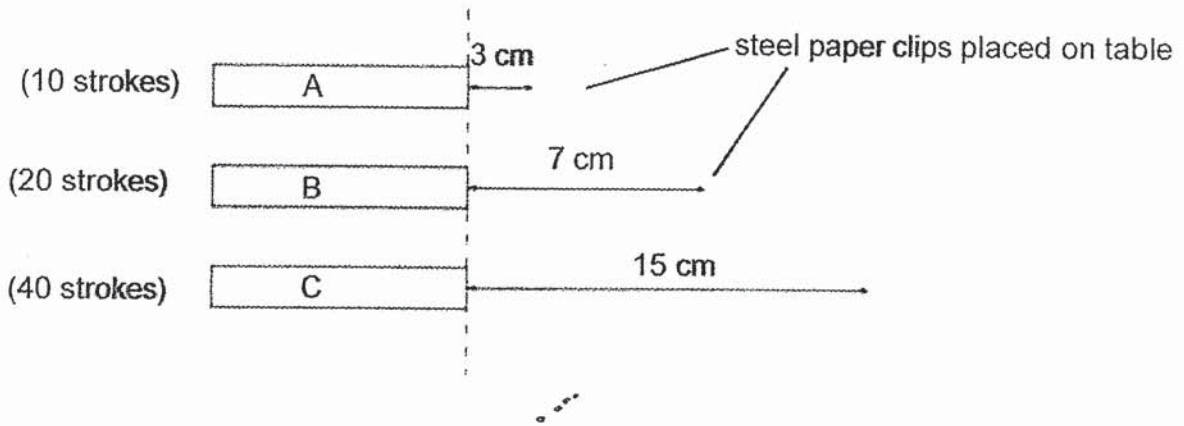

(a) What is/are the force(s) that will affect the maximum distance at which the iron bars would attract the steel paper clips? [1]

(b) Based on the experiment, which iron bar, A, B or C, has the greatest magnetic strength? Explain your answer. [1]

Max hit iron bar A with a hammer and it broke into two pieces.

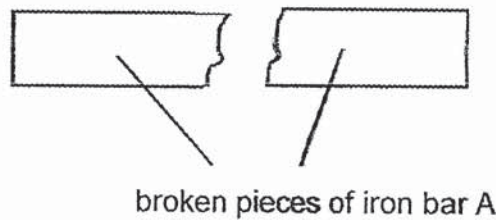

(c) Based on the diagram above, what is the effect of the force on the iron bar A? [1]

- (d) Explain how you will conduct a test to find out if the broken pieces of iron bar A is still a temporary magnet. [2]

End of Paper

Score	5
-------	---

NHPS P6 Science Prelims 2021

ANSWER

Section A

Question	Answer	Question	Answer	Question	Answer
1	3	11	3	21	2
2	4	12	3	22	2
3	3	13	2	23	1
4	3	14	4	24	1
5	2	15	3	25	1
6	3	16	2	26	2
7	1	17	4	27	4
8	1	18	3	28	3
9	2	19	2		
10	2	20	2		

Q	Answer	
29a	They are grouped based on their reproduction method.	1
29b	One reproduce by seeds. The other reproduce by spores.	
30a	Bees transfer pollen from the male part.	
30bi	(i) The fibrous husk trap/contain air (spaces) (1/2), which helps it to float on water (1/2)/ dispersed by water.	
30bi	(ii) to compete less for space/sunlight/ water/ nutrients/ mineral salts	
31a	System 1 : Muscular system System 2: Skeletal system	1/2 1/2
31b	Oxygen and digested food is transported through the blood vessels in the circulatory system to the muscle cells, which gives the cells the energy to lift the bag of books.	2
32a	the amount of roots the size of the leaves	1
32b	Graph E	1
32c	$1000 - 600 - 100 = 300\text{cm}^3$ Take the difference between the amount of water left in setup C with the amount of water left in setup B.	1
32d	To find out the amount of water that has evaporated from the beaker.	1
33a	The amount of oxygen decreases over the 30 minutes as the family will need to take in oxygen for respiration and energy is released for the actions to occur.	1
33b	More oxygen will be taken into the body to release more energy for jumping and kicking the door.	1
34a	Photosynthesis is a process that uses carbon dioxide and water, in the presence of light and chlorophyll, to make oxygen and food.	1

34b	David observed more bubbles in set-up A.	1
34c	1) remove substance Q 2) put set up A in a dark room	$\frac{1}{2}$ $\frac{1}{2}$
35a	Stone : Solid Air : gaseous/gas states	0.5 0.5
35b	Above 150 cm ³ <input checked="" type="checkbox"/>	1
35c	There is some spaces between the stones in the container. As air is a matter and occupy space the volume of the container is more than 150 cm ³ .	1
35d	4, 2, 1, 3	1
36a	Water from the seawater gains heat from the Sun (1/2) and evaporates to form water vapour (1/2). The water vapour loses heat to the colder surface of the glass cover (1/2) and condensed into water droplets (1/2). The water droplets, which is the pure water, is then collected in the container.	2
36b	The temperature of the surroundings is the highest (1/2) at 12pm, resulting in the highest/fastest rate of evaporation (1/2).	1
37a	Into beaker B.	1
37b	28°C/ Room temperature	1
37c	The water in beaker A gains heat from the surroundings until it reaches room temperature.	1
37d	By adding cold water/ ice. Use a fan to blow at the beaker of water.	1
38a	A: Gravitational potential B: Kinetic C: Gravitational potential + Kinetic	1
38b	The layer of oil will reduce the friction between skateboard and the ramp.	1
38c	The end of the ramp is higher than where he started from (1). Hence the amount of gravitational potential energy converted into kinetic energy is not enough (1) for him to go higher than his starting height.	2
39a		2

39b	The bulbs would be dimmer (1). The bulbs were arranged in series and hence electric current passing through the bulbs was reduced (1).	2
40a	Liquids have no definite shape.	1
40b	Can of Design B has a larger surface area in contact with the cold surroundings (1). Hence the milk in the can lose heat faster. (1)	2
41a	Magnetic force and friction	1
41b	Iron bar C has the greatest magnetic strength. It was given the largest number of strokes (1/2) and it attract the steel paper clip at the furthest distance (1/2).	1
41c	The force changes the shape of the object.	
41d	Place the North pole of a magnet on all the ends of the broken pieces of the iron bar A (1/2). Place the South pole of a magnet on all the ends of the broken pieces of the iron bar A (1/2). If there is repulsion from the ends of the broken pieces of iron bar A, it means that it is still a temporary magnet (1).	2

3
END