



**Maha Bodhi School**  
**2021 Semestral Assessment 2**  
**Primary 5**  
**Mathematics**  
**Paper 1**  
**(Booklet A)**

Name : \_\_\_\_\_ (       )

Class : Primary 5 \_\_\_\_\_

Date : 29 October 2021

Total duration for Booklets A and B: 1 hour

---

**INSTRUCTIONS TO CANDIDATES:**

1. Do not turn over this page until you are told to do so.
  2. Follow all instructions carefully.
  3. Answer all questions.
  4. Shade your answers in the Optical Answer Sheet provided.
  5. The use of calculators is **NOT** allowed.
-

Questions 1 to 10 carry 1 mark each. Questions 11 to 15 carry 2 marks each.  
For each question, four options are given. One of them is the correct answer.  
Make your choice (1, 2, 3 or 4) and shade your answer on the Optical Answer Sheet.  
(20 marks)

---

1. In 5 475 830, what is the value of the digit 7?

- (1) 70
- (2) 700
- (3) 7000
- (4) 70 000

2. Which of the following fractions is the greatest?

- (1)  $\frac{1}{7}$
- (2)  $\frac{1}{5}$
- (3)  $\frac{1}{3}$
- (4)  $\frac{1}{9}$

3. Write  $\frac{2}{25}$  as a decimal.

- (1) 0.08
- (2) 0.225
- (3) 0.8
- (4) 2.25

4. Which one of the following is likely to be the height of the classroom door?

- (1) 2100 m
- (2) 210 m
- (3) 21 m
- (4) 2.1 m

5. Which of the following lines below is a line of symmetry of the figure?

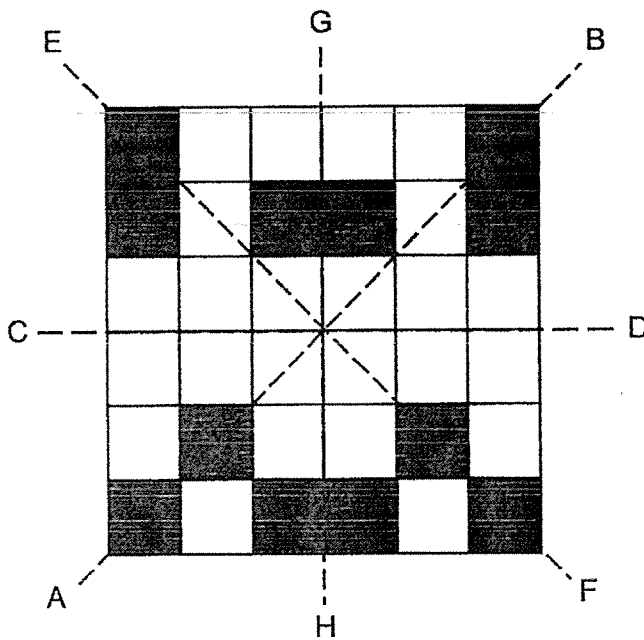

- (1) AB
- (2) CD
- (3) EF
- (4) GH

6. What is the area of triangle ABC as shown in the figure?

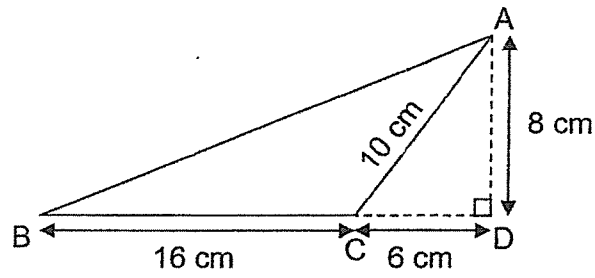

- (1)  $64 \text{ cm}^2$
- (2)  $80 \text{ cm}^2$
- (3)  $88 \text{ cm}^2$
- (4)  $128 \text{ cm}^2$

7. A machine can print 8 posters in 1 minute.  
At this rate, how many posters can it print in 2 hours?

- (1) 16
- (2) 480
- (3) 960
- (4) 1600

8. The bar graph below shows the number of bicycles sold in a shop from February to May.

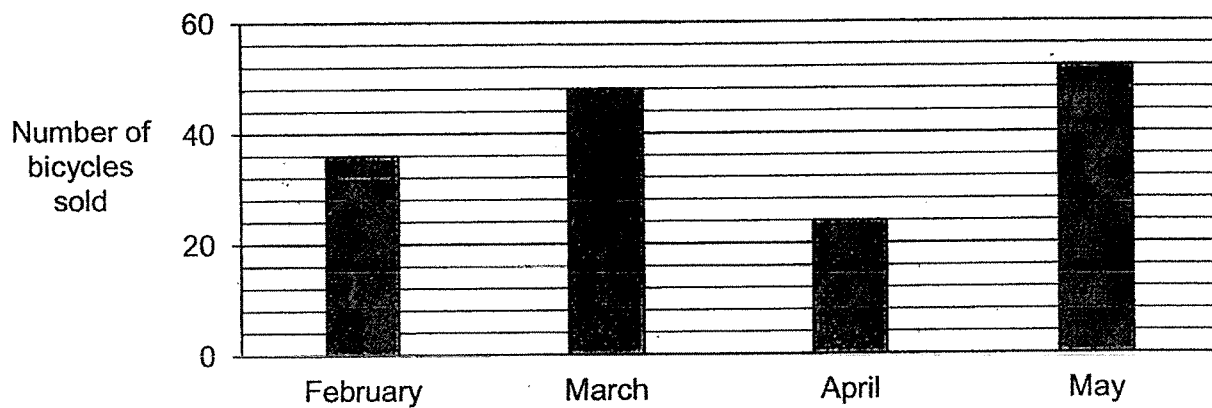

How many bicycles were sold in March?

- (1) 42
  - (2) 44
  - (3) 48
  - (4) 54
9. What is the value when 375 000 is divided by 6000?

- (1) 6.25
- (2) 62.5
- (3) 625
- (4) 6250

10. How many eighths are there in  $3\frac{3}{4}$ ?

- (1) 13
- (2) 15
- (3) 26
- (4) 30

11. Benjamin used  $20\,000\text{ cm}^3$  of liquid cement to make similar bricks as shown below.

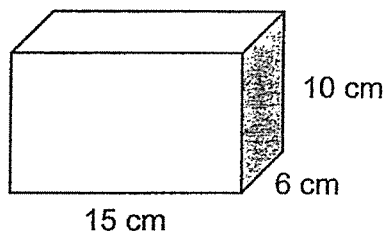

How many such bricks can Benjamin get?

- (1) 22
- (2) 23
- (3) 222
- (4) 223

12. There was a sale at a bakery with information as shown in the poster below.

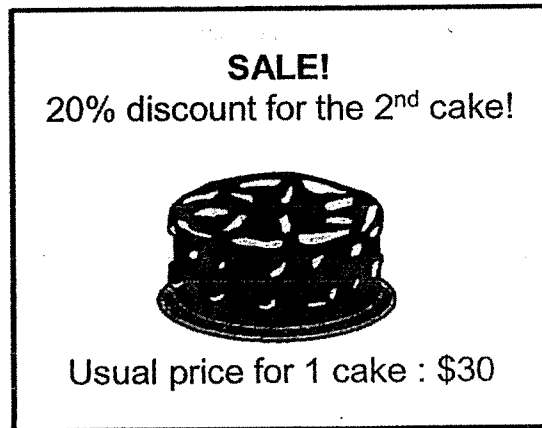

How much did Nicole pay for 2 cakes during the sale?

- (1) \$24  
(2) \$36  
(3) \$48  
(4) \$54
13. The airmail rates to two countries are shown below.

	<b>China</b>	<b>New Zealand</b>
First 20 g	\$0.80	\$1.40
Every additional 10 g	\$0.25	\$0.35

David sent a letter weighing 34 g to China and a letter weighing 10 g to New Zealand by airmail. How much did he pay altogether?

- (1) \$1.65  
(2) \$2.45  
(3) \$2.70  
(4) \$2.80

14. Devi was supposed to multiply a number by 300.  
Instead, she multiplied the number by 30.  
The difference between her answer and the actual answer is 67.5.  
What is the number?
- (1) 7.5  
(2) 6.75  
(3) 0.25  
(4) 0.225
15. The average height of some boys is 124 cm.  
When 3 girls, with a total height of 324 cm, are included, the average height of the children becomes 118 cm.  
How many children are there altogether?
- (1) 10  
(2) 8  
(3) 6  
(4) 5



*Remember to check your work!  
~ End of Booklet A ~*

---

This is the property of Maha Bodhi School.  
No part of this should be duplicated without the permission of Maha Bodhi School.





**Maha Bodhi School**  
**2021 Semestral Assessment 2**  
**Primary 5**  
**Mathematics**  
**Paper 1**  
**(Booklet B)**

Name : \_\_\_\_\_ (       )

Marks:

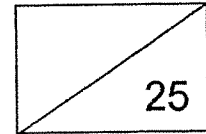

Class : Primary 5 \_\_\_\_\_

Date : 29 October 2021

Total duration for Booklets A and B: 1 hour

---

**INSTRUCTIONS TO CANDIDATES:**

1. Do not turn over this page until you are told to do so.
2. Follow all instructions carefully.
3. Answer all questions.
4. Write all your answers in this booklet.
5. The use of calculators is **NOT** allowed.

This booklet consists of 7 printed pages.

Questions 16 to 20 carry 1 mark each. Write your answers in the spaces provided.  
For questions which require units, give your answers in the units stated. (5 marks)

---

16. What is the volume of the cube shown below?

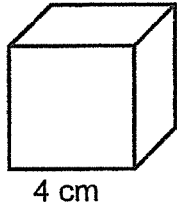

Ans: \_\_\_\_\_  $\text{cm}^3$

17. In the figure below, PQ and RS are straight lines. Which two angles are equal?

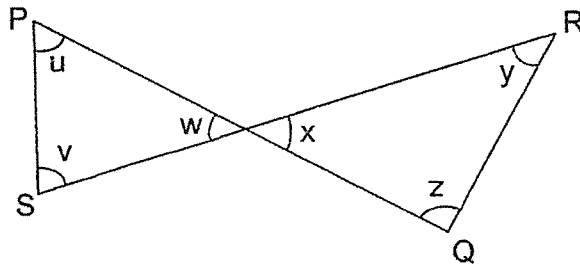

Ans:  $\angle$  \_\_\_\_\_ and  $\angle$  \_\_\_\_\_

18. Kelly needed 2 cups of sugar to make 12 fruit tarts.

She wanted to bake 30 such fruit tarts. How many cups of sugar would she need?

Ans: \_\_\_\_\_

19. The bar graph below shows the test scores for a group of pupils.

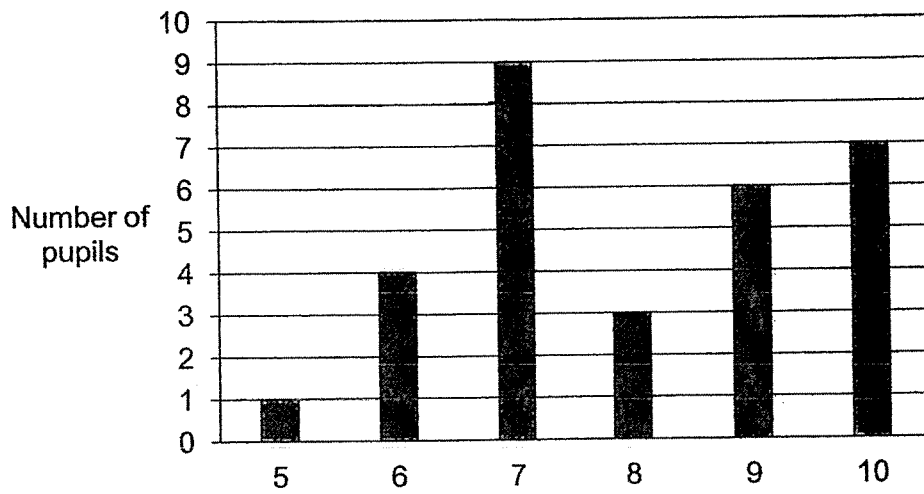

How many pupils scored 8 marks and above?

Ans: \_\_\_\_\_

20. The diagram below shows the seating plan of a classroom.  
Who is sitting north-west of Ali?

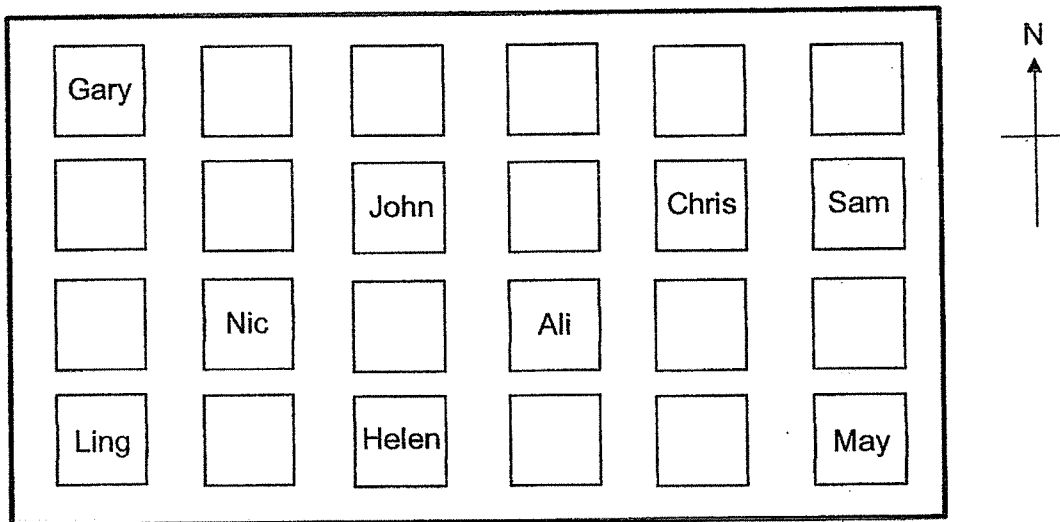

Ans: \_\_\_\_\_

Questions 21 to 30 carry 2 marks each. Show your working clearly in the space below each question and write your answers in the spaces provided.  
For questions which require units, give your answers in the units stated. (20 marks)

---

21. Find the value of  $140 \div 5 - (2 + 8) \times 2$ .

Ans: \_\_\_\_\_

22. What is the sum of  $2\frac{5}{6}$  and  $\frac{3}{4}$  ?

Give your answer as a mixed number in the simplest form.

Ans: \_\_\_\_\_

23. Lester started doing his homework at 14 25 and completed it at 17 05.  
He took a 30-minute break in between. How long did he spend doing his homework?

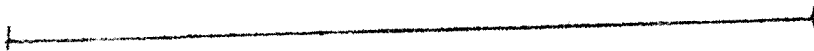

Ans: \_\_\_\_\_ h \_\_\_\_\_ min

24. The diagram below shows the distances between different attractions at an amusement park.

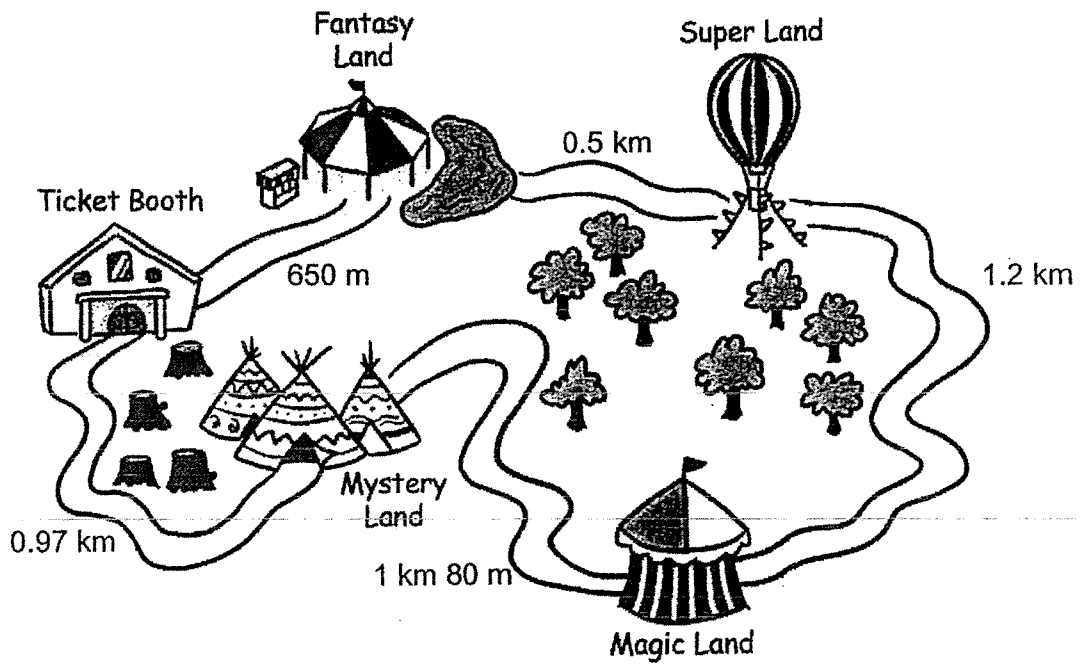

Dora took the shortest route to walk from the ticket booth to Magic Land. Find the distance she walked in km.

Ans: \_\_\_\_\_ km

25. What are the missing numbers in the boxes?

$$\boxed{A} : 4 : 5 = 27 : \boxed{B} : 45$$

Ans: A = \_\_\_\_\_

B = \_\_\_\_\_

26. Alex receives \$5 for his pocket money every day. The table below shows the amount of pocket money he spent each day from Monday to Friday.

Day	Monday	Tuesday	Wednesday	Thursday	Friday
Amount Alex spent	\$3.80	\$2.50	\$4	\$4.30	\$2

Alex saves what is left of his pocket money each day.

On which day did he save the most?

Ans: \_\_\_\_\_

27. Mrs Tan bought some vegetables at the market. She tore the receipt accidentally.

ABC Vegetable Stall	
12 October 2021	
Cauliflower	\$2.7
Carrots	\$1.
-----	
Total	
Change	

Each of the statements below is either true, false or not possible to tell from the information given. For each statement, put a tick (✓) to indicate your answer.

Statement	True	False	Not possible to tell
The least possible total amount Mrs Tan spent was \$3.70.			
Mrs Tan gave the cashier \$10 and received a change of \$5.10.			

28. Jane stacked 8 unit cubes and glued them together to form the solid below.

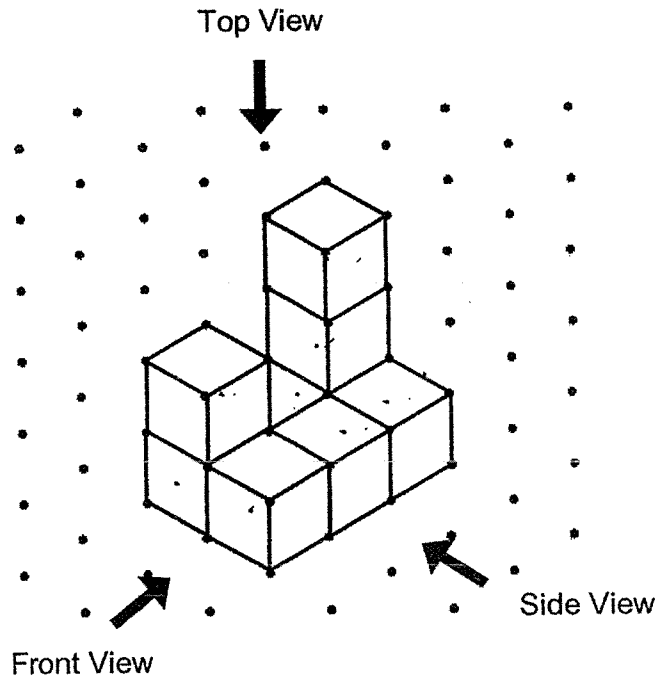

<p>(a) The top view of the solid is shown below. <b>Mark a cross (X)</b> on the face that is not drawn correctly.</p>	<p>(b) One of the faces in the side view of the solid is missing. <b>Draw</b> the missing face to complete the side view of the solid.</p>
<p><u>Top View</u></p>	<p><u>Side View</u></p>

29. A total of 127 people were in a queue to collect their TraceTogether tokens.  
 There are at least 3 women between any 2 men.  
 What is the greatest possible number of men in the queue?

Ans: \_\_\_\_\_

30. In the figure, XYZ and LMN are triangles. ZLX, XMY and ZNY are straight lines.  
 Find  $\angle a + \angle b + \angle c + \angle d + \angle e + \angle f$ .

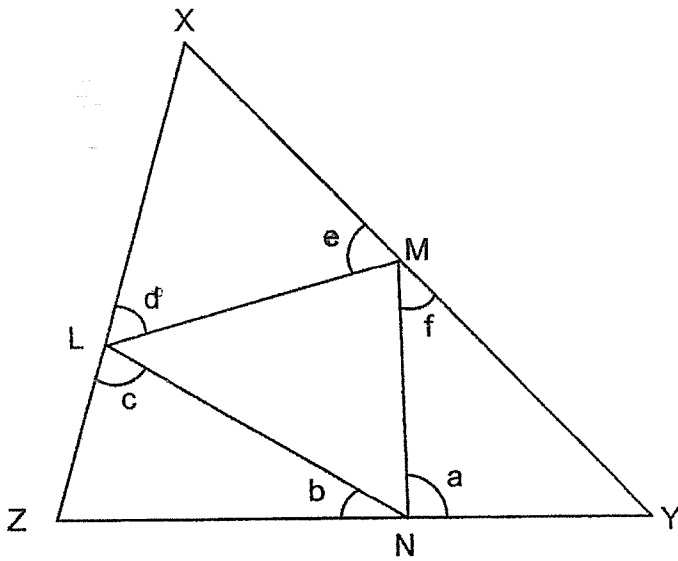

Ans: \_\_\_\_\_<sup>o</sup>



*Remember to check your work!  
 ~ End of Booklet B ~*

/ 4
-----

This is the property of Maha Bodhi School.  
 No part of this should be duplicated without the permission of Maha Bodhi School.





**Maha Bodhi School**  
**2021 Semestral Assessment 2**  
**Primary 5**  
**Mathematics**  
**Paper 2**

Name : \_\_\_\_\_ (    )

Class : Primary 5 \_\_\_\_\_

Date : 29 October 2021

Duration: 1 h 30 min

---

**INSTRUCTIONS TO CANDIDATES:**

1. Do not turn over this page until you are told to do so.
2. Follow all instructions carefully.
3. Answer all questions.
4. Write your answers in this booklet.
5. The use of an approved calculator is expected, where appropriate.

Paper	Booklet	Marks Obtained	Max Marks
1	A		20
	B		25
2	-		55
<b>Total</b>			<b>100</b>

Parent's signature: \_\_\_\_\_

This booklet consists of **13** printed pages.

Questions 1 to 5 carry 2 marks each. Show your working clearly in the space provided for each question and write your answers in the spaces provided. For questions which require units, give your answers in the units stated. (10 marks)

---

1.  $\frac{1}{3}$  of a number is 45. What is 40% of the number?

Ans: \_\_\_\_\_

2. There were 13 sweets in a packet. Mrs Fong bought a few packets of such sweets. After giving 3 sweets to each of her 27 students, she still had 10 sweets left. How many packets of sweets did she buy?

Ans: \_\_\_\_\_

3. Lijie has some empty big bottles and 9 empty small bottles. The capacity of the big bottle is 2 ℓ and the capacity of the small bottle is 0.75 ℓ. A total of 28.75 ℓ of water is needed to completely fill up all the bottles. How many big bottles does Lijie have?

Ans: \_\_\_\_\_

4. Ben bought 2 bags of garden soil and a bag of compost for his garden.

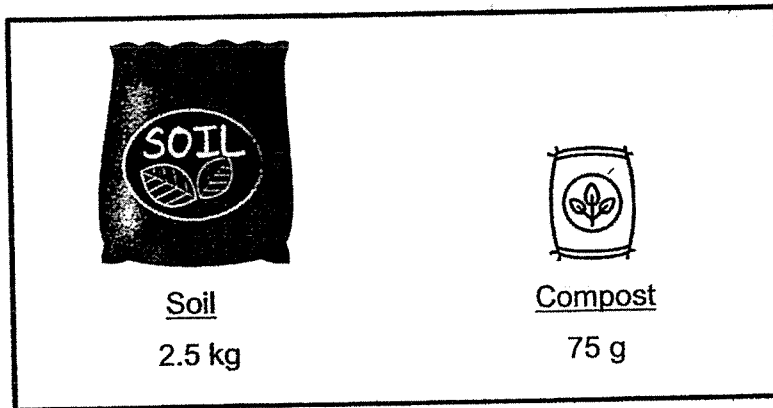

He used up all the three bags to make some potting mix. He poured the potting mix equally into 5 flowering pots. How much potting mix was in each flowering pot?  
Give your answer in kg.

Ans: \_\_\_\_\_ kg

5. The table below shows the charges for water consumption.

First 40 m <sup>3</sup>	\$1.21 per m <sup>3</sup>
Every additional m <sup>3</sup>	\$1.52 per m <sup>3</sup>

Mr Li's family used 50 m<sup>3</sup> of water for the month. How much must Mr Li pay?

Ans: \$ \_\_\_\_\_

For questions 6 to 17, show your working clearly in the space provided for each question and write your answers in the spaces provided. The number of marks available is shown in brackets [ ] at the end of each question or part-question. (45 marks)

6. In the square grid below, one side of the triangle XYZ has been drawn.

(a) Complete triangle XYZ by drawing 2 more lines in the grid.

$\angle XYZ = 90^\circ$  and  $XY = YZ$ .

[2]

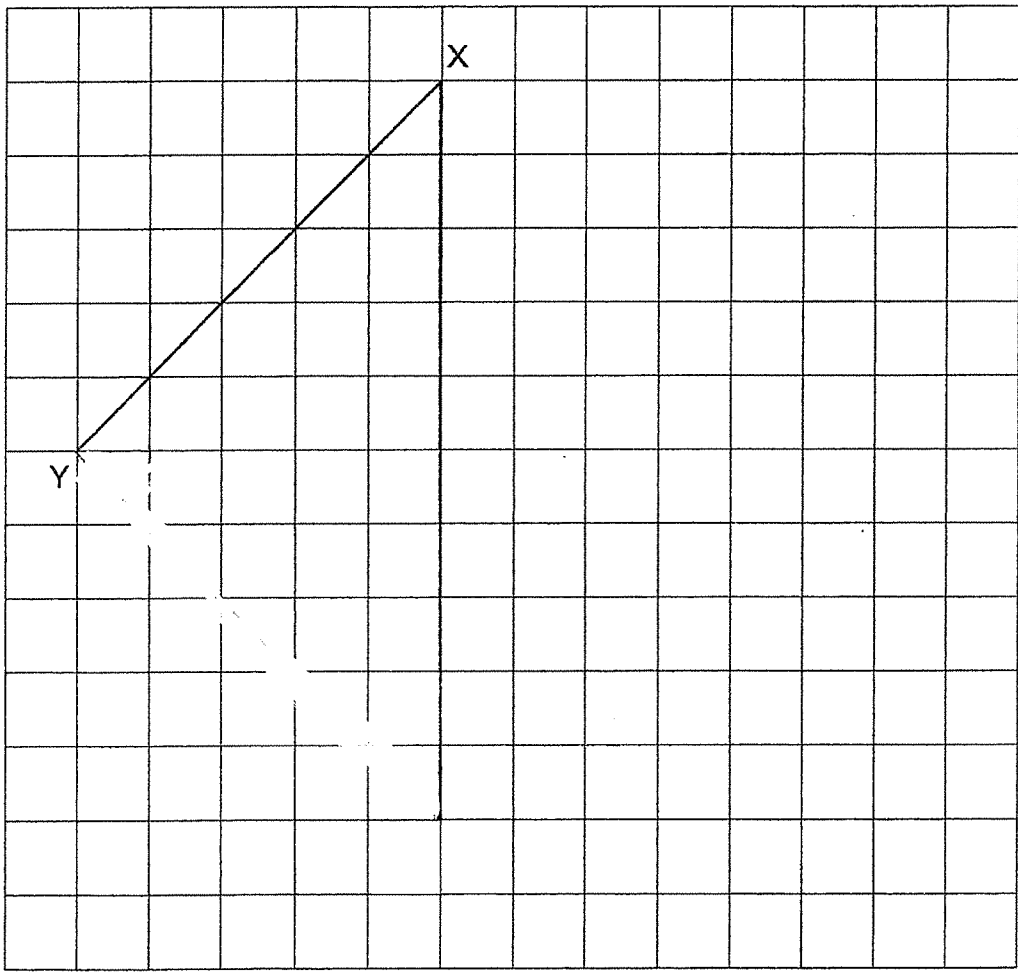

(b) Circle the word that describes  $\angle YXZ$  correctly.

[1]

$\angle YXZ$  is a/an ( acute / right / obtuse ) angle.

7. Stella had some stickers at first. She gave  $\frac{2}{9}$  of her stickers to her brother and  $\frac{1}{6}$  of her stickers to her best friend. After that, her mother gave her another 10 stickers. She had 87 stickers in the end. How many stickers did Stella have at first?

Ans: \_\_\_\_\_ [3]

8. Mrs Goh gave some money to her three children, Albert, Benny and Carl in the ratio 2 : 9 : 5. Benny received \$308 more than Albert. How much did Mrs Goh give to her children altogether?

Ans: \_\_\_\_\_ [3]

9. The usual price of a laptop is \$2450. Jun Hao bought it at a discount of 30%.

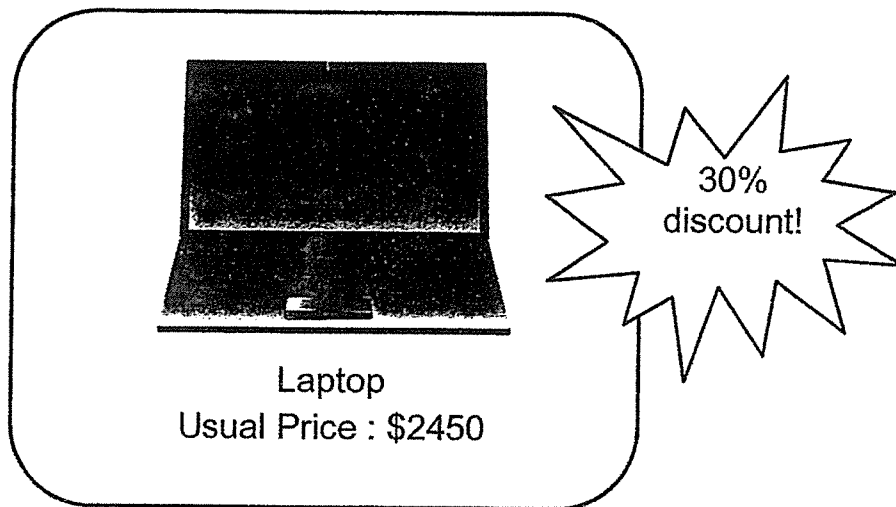

Jun Hao had to pay a GST of 7% on the discounted price of the laptop.  
How much was the GST?

Ans: \_\_\_\_\_ [3]

10. ABCD is a rectangular piece of paper.  
 Corners C and D are folded upwards as shown below.  
 $\angle CFG = 23^\circ$  and  $\angle DFE = 16^\circ$ .

- (a) Find  $\angle CGF$ .  
 (b) Find  $\angle DFC$ .

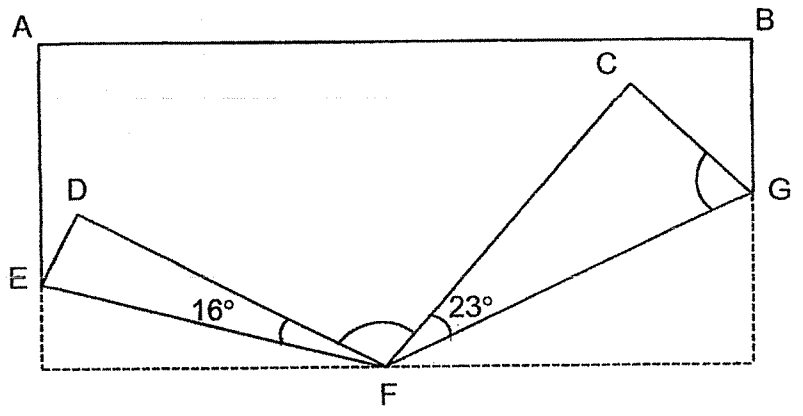

Ans: (a) \_\_\_\_\_ [1]

(b) \_\_\_\_\_ [2]

11. White and grey squares are used to form the figures as shown below.

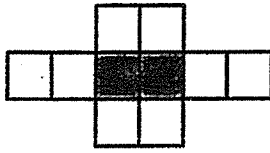

Figure 1

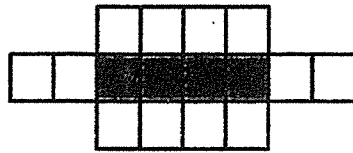

Figure 2

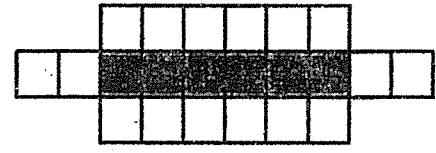

Figure 3

- (a) How many grey squares are there in Figure 8?
- (b) How many white squares are there in Figure 15?
- (c) Which figure will have 120 white squares?

Ans: (a) \_\_\_\_\_ [1]

(b) \_\_\_\_\_ [1]

(c) Figure \_\_\_\_\_ [2]



12. Bala saved some money in the form of 20¢, 50¢ and \$1 coins.  
There was an equal number of 50¢ and \$1 coins.  
The number of 50¢ coins was twice as many as the number of 20¢ coins.  
The difference in the value of 50¢ coins and \$1 coins was \$12.
- (a) How many 50¢ coins did he have?
  - (b) How much did he save in total?
  - (c) After exchanging some of his \$1 coins for 20¢ coins, he had an equal number of \$1 coins and 20¢ coins. How many 20¢ coins did he have in the end?

Ans: (a) \_\_\_\_\_ [1]

(b) \_\_\_\_\_ [2]

(c) \_\_\_\_\_ [1]

13. WQY is an isosceles triangle.  $WY = WQ$ .  
 PQR is a right-angled triangle and  $\angle PRQ = 34^\circ$ .  
 WPQ, RYQ, WXY and PXR are straight lines.

- (a) Find  $\angle QWY$ .  
 (b) Find  $\angle PXY$ .

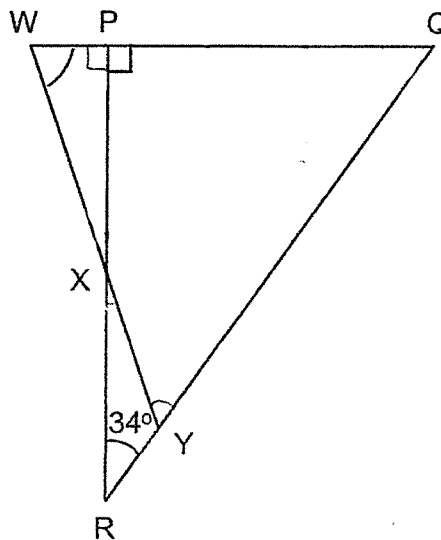

Ans: (a) \_\_\_\_\_ [2]

(b) \_\_\_\_\_ [2]

14. The graph below shows the height of a plant from March to July.

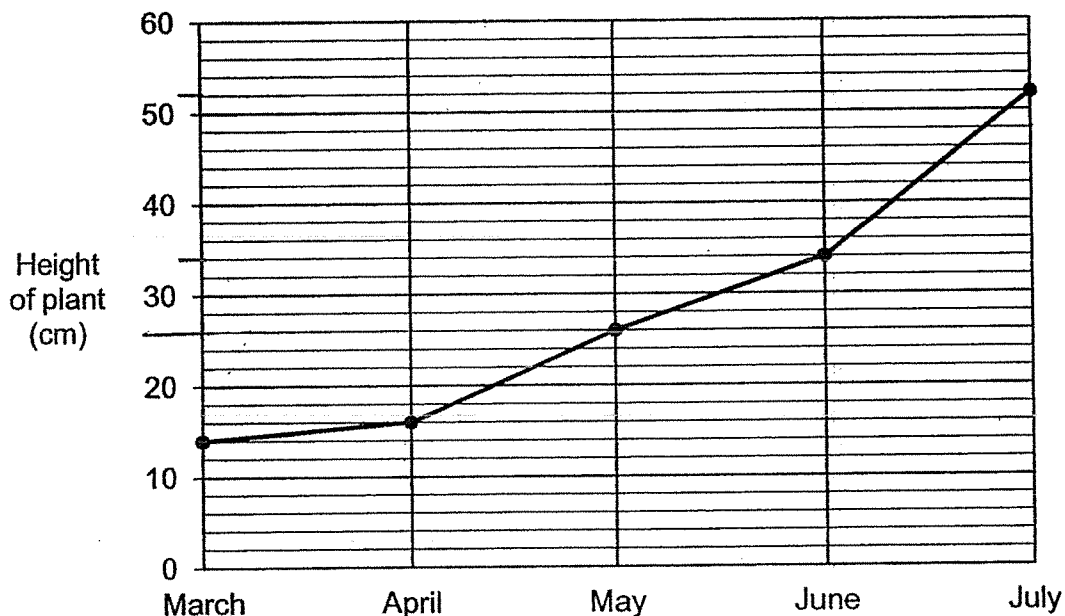

(a) The table below shows the increase in the height of the plant when compared to the previous month. Complete the table below. [1]

	April	May	June	July	August
Increase in height (cm)	2	10			6

- (b) What was the height of the plant in August?  
 (c) What was the average height of the plant from March to July?

Ans: (b) \_\_\_\_\_ [1]

(c) \_\_\_\_\_ [2]

15. In the figure below, PQRS is a rectangle with a perimeter of 84 cm. PU, PR, TU and TR are straight lines. The length of PQ is twice the length of QR.

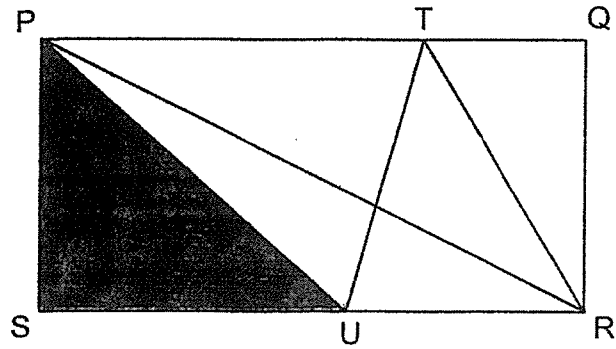

- (a) What is the area of rectangle PQRS?
- (b) Given that the area of triangle TRU is  $91 \text{ cm}^2$ , find the area of triangle SPU.

Ans: (a) \_\_\_\_\_ [2]

(b) \_\_\_\_\_ [2]

16. A box of pies cost \$15 while a box of muffins cost \$17.  
Each box contained either 4 pies or 3 muffins.  
Mrs Silva bought the same number of pies and muffins.  
She paid \$207 more for the muffins. How many boxes of pies did she buy?

Ans: \_\_\_\_\_ [5]

17. At a carnival, the children were put into two groups.

$\frac{2}{3}$  of Group A were boys and  $\frac{3}{5}$  of Group B were girls.

Group B had twice as many children as Group A.

There were 26 fewer boys in Group A than Group B.

(a) What fraction of the total number of children at the carnival were boys?

Give your answer in the simplest form.

(b) What was the total number of children at the carnival?

Ans: (a) \_\_\_\_\_ [2]

(b) \_\_\_\_\_ [3]



*Remember to check your work!  
~ End of Paper ~*

\_\_\_\_\_ / 5

---

This is the property of Maha Bodhi School.  
No part of this should be duplicated without the permission of Maha Bodhi School.

## ANSWER KEY

**YEAR : 2021**  
**LEVEL : Primary 5**  
**SCHOOL : Maha Bodhi School**  
**SUBJECT : MATHEMATICS**  
**TERM : SA2**

### BOOKLET A (PAPER 1)

Q1	4	Q2	3	Q3	1	Q4	4	Q5	4
Q6	1	Q7	3	Q8	3	Q9	2	Q10	4
Q11	1	Q12	4	Q13	3	Q14	3	Q15	2

### BOOKLET B (PAPER 1)

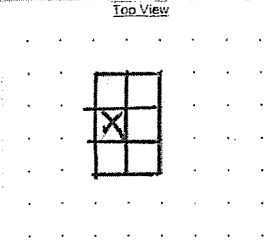
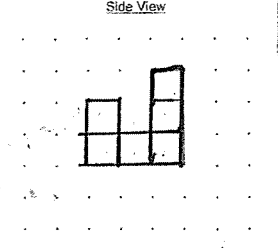
Q16	$4 \times 4 \times 4 = 64$	Q17	W and X
Q18	$12 \div 2 = 6$ $30 \div 6 = 5$	Q19	$3+6+7=16$
Q20	John	Q21	8
Q22	$2\frac{5}{6} + \frac{3}{4} = 3\frac{7}{12}$	Q23	2h 10min
Q24	$1080+970=2050$ $2050\text{m}=2.05\text{km}$	Q25	$45 \div 5 = 9$ $27 \div 9 = 3$ $4 \times 9 = 36$ Ans : A=3 B=36
Q26	Friday	Q27	True False
Q28	<p>(a) The top view of the solid is shown below. Mark a cross (X) on the face that is not drawn correctly.</p> <p style="text-align: center;">Top View</p>  <p>(b) One of the faces in the side view of the solid is missing. Draw the missing face to complete the side view of the solid.</p> <p style="text-align: center;">Side View</p> 	Q29	$127 \div 4 = 31R3$ $31+1=32$
Q30	$180+180=180=540$ $540-180=360$		

**PAPER 2**

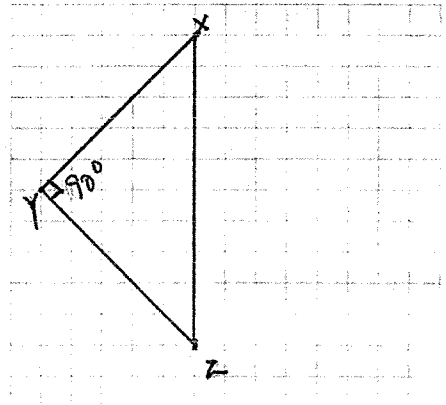
Q1	$45 \times 3 = 135$ $\frac{40}{100} \times 135 = 54$	Q2	$27 \times 3 = 81$ $81 + 10 = 91$ $91 \div 13 = 7$
Q3	$9 \times 0.75 = 6.75$ $28.75 - 6.75 = 22$ $22 \div 2 = 11$	Q4	$2.5 + 2.5 + 0.075 = 5.075$ $5.075 \div 5 = 1.015$
Q5	$1.1 \times 40 = 48.4$ $50 - 40 = 10$ $10 \times 1.52 = 15.2$ $48.4 + 15.2 = 63.60$	Q6	(a)  (b) acute
Q7	$87 - 10 = 77$ $77 \div 11 = 7$ $7 \times 18 = 126$	Q8	$9 - 2 = 7$ $308 \div 7 = 44$ $2 + 9 + 5 = 16$ $44 \times 16 = 704$
Q9	$100 - 30 = 70$ $\frac{70}{100} \times 2450 = 1715$ $\frac{7}{100} \times 1715 = \$120.05$	Q10	(a) $180 - 90 - 23 = 67^\circ$ (b) $180 - 16 - 16 - 23 - 23 = 102^\circ$
Q11	(a) $2 \times 8 = 16$ (b) $15 \times 4 + 4 = 64$ (c) $120 - 4 = 116$ $116 \div 4 = 29$	Q12	(a) $12 \div 0.50 = 24$ (b) $1 \times 24 = 24$ $0.50 \times 24 = 12$ $24 \div 2 = 12$ $12 \times 0.20 = 2.40$ $24 + 12 + 2.40 = \$38.40$ (c) $12 + 10 = 22$
Q13	(a) $180 - 90 - 34 = 56$ $180 - 56 - 56 = 68^\circ$ (b) $180 - 90 - 68 = 22$ $180 - 22 = 158^\circ$	Q14	(a) 8, 18 (b) $52 + 6 = 58\text{cm}$ (c) $(14 + 16 + 26 + 34 + 52) \div 5 = 28$
Q15	$84 \div 2 = 42$ $42 \div 3 = 14$ $14 \times 2 = 28$	Q16	$3 \times 12 = 36$ $36 \div 4 = 9$ $9 \times 15 = 135$



	$28 \times 14 = 392 \text{cm}^2$ <b>(b) <math>91 \times 2 = 182</math></b> $392 - 182 = 210$ $210 \div 2 = 105 \text{cm}^2$		$36 \times 3 = 108$ $108 \div 3 = 36$ $108 \div 4 = 27$ $36 \times 17 = 612$ $27 \times 15 = 405$ <b>Ans : 27</b>
<b>Q17</b>	<b>(a) <math>10 + 12 = 22</math></b> $15 + 30 = 45$ <b>Ans : <math>\frac{22}{45}</math></b> <b>(b) <math>26 \div 2 = 13</math></b> $45 \times 13 = 585$		