



NAN HUA PRIMARY SCHOOL
END-OF-YEAR EXAMINATION 2020
PRIMARY 4

SCIENCE

BOOKLET A

28 Multiple Choice Questions (56 marks)

Total Time for Booklets A and B : 1 hour 45 minutes

INSTRUCTIONS TO CANDIDATES

1. Write your name and index number in the space provided.
2. Do not turn over the page until you are told to do so.
3. Follow all instructions carefully.
4. Answer all questions.
5. Shade your answers in the Optical Answer Sheet (OAS) provided.

Marks Obtained

| | | |
|-----------|--|-------|
| Booklet A | | / 56 |
| Booklet B | | / 44 |
| Total | | / 100 |

Name: _____ () Class: P

Date: 28 October 2020

Parent's Signature: _____

Section A: (28 x 2 marks = 56 marks)

For each question from 1 to 28, four options are given. One of them is the correct answer. Make your choice (1, 2, 3 or 4) and shade your answer on the Optical Answer Sheet.

1 Which one of the following statements is true for ALL insects?

- (1) They have tails.
- (2) They live on land.
- (3) They have wings.
- (4) They have six legs.

2 The diagram shows a plant.

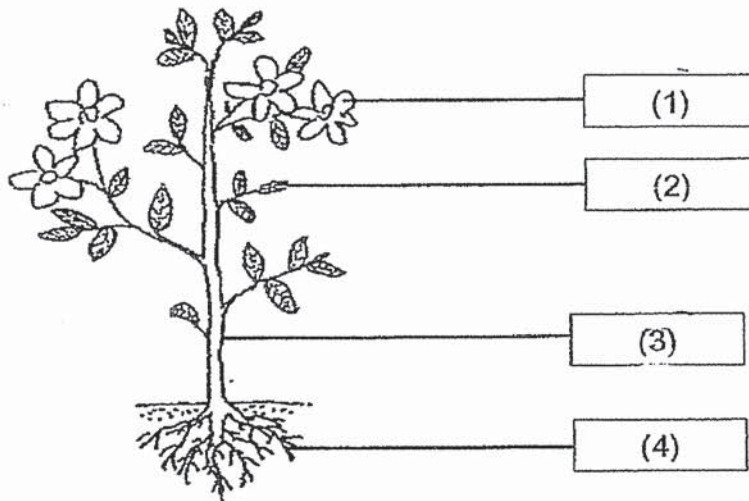

Which part, (1), (2), (3) or (4), is the stem?

3 In which part of the digestive system is food absorbed into the blood?

- (1) mouth
- (2) stomach
- (3) small intestine
- (4) large intestine

4 The diagram shows the life cycle of a plant.

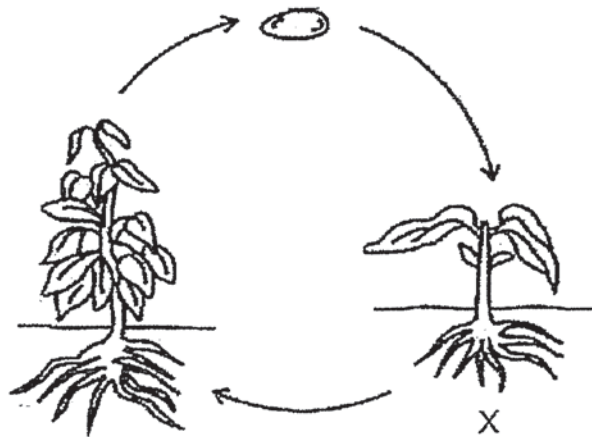

What is the stage marked X?

- (1) egg
- (2) seed
- (3) adult plant
- (4) young plant

5 Which animal has a pupa as a stage in its life cycle?

- (1) frog
- (2) chicken
- (3) mosquito
- (4) cockroach

- 6 The diagram shows a window inside a bedroom.

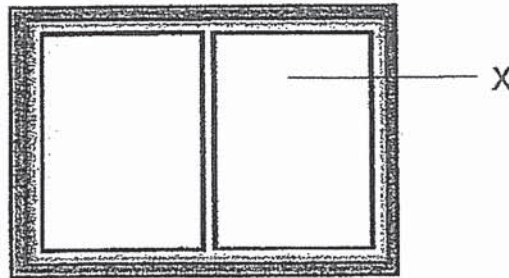

Glass is used to make part X because it _____.

- (1) is flexible
 - (2) breaks easily
 - (3) sinks in water
 - (4) is transparent
- 7 Which one of the following can be attracted by a magnet?
- (1) steel ball
 - (2) rubber ball
 - (3) ceramic ball
 - (4) wooden ball
- 8 Which one of the following is **NOT** a source of heat?
- (1) the sun
 - (2) a candle flame
 - (3) a pot of hot water
 - (4) a woollen sweater

9 Which one of the following is a source of light?

(1)



an apple

(2)



a tree

(3)



the moon

(4)



a candle flame

10 Study the diagram below.

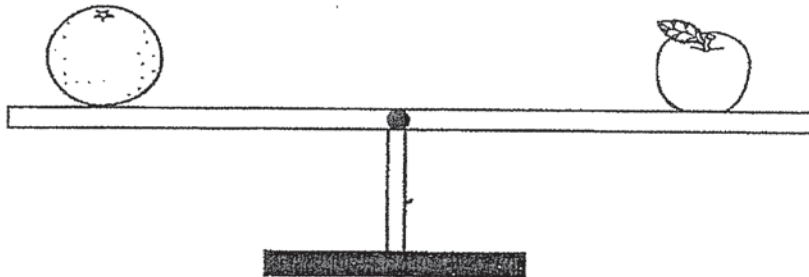

Which of the following statements is true?

- (1) Both fruits have the same size.
- (2) Both fruits have the same mass.
- (3) Both fruits have the same shape.
- (4) Both fruits have the same volume.

11 The pictures below show a young chick becoming an adult chicken.

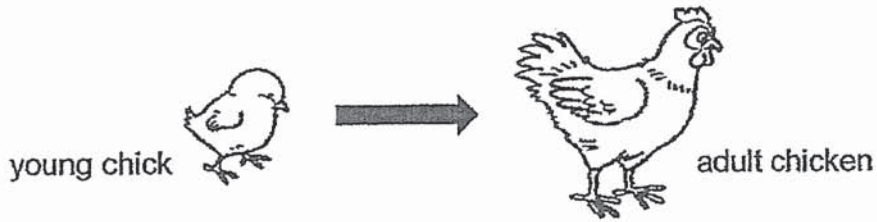

This shows that the chicken is a living thing because it _____.

- (1) can grow
- (2) can reproduce
- (3) can respond to changes
- (4) needs air, food and water to survive

12 The classification chart below shows how some animals can be grouped according to their outer coverings.

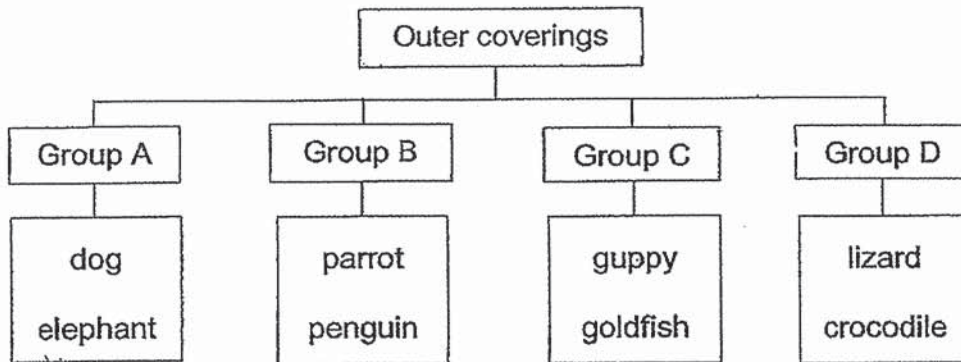

Animal X has the following characteristics:

| | |
|---------------|---------------------------|
| Has a beak | Has feathers |
| Has two wings | Reproduces by laying eggs |

Which group should Animal X be placed in?

- (1) Group A
- (2) Group B
- (3) Group C
- (4) Group D

- 13 Ramesh took two glass beakers, X and Y, and filled each of them with 200 ml of water. He then put a balsam plant in beaker Y only. Both beakers were covered and left by an open window for a few days as shown below.

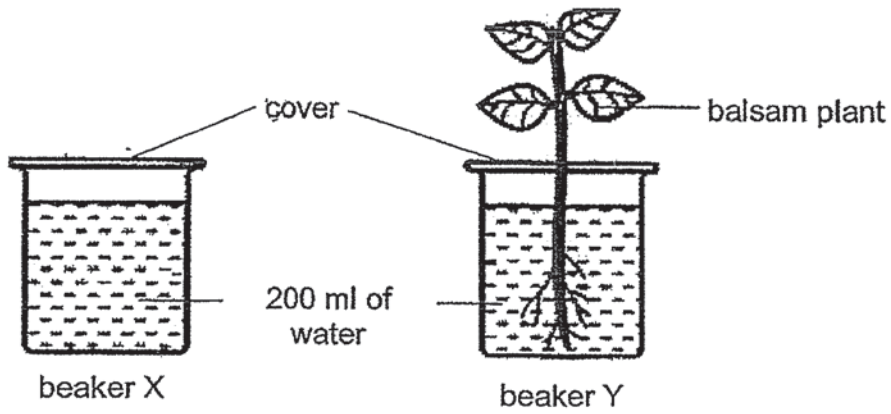

Which of the following sets would he expect to see after a few days?

| | | | |
|-----|-------------------------------|-----|-------------------------------|
| (1) | <p>beaker X beaker Y</p> | (2) | <p>beaker X beaker Y</p> |
| (3) | <p>beaker X beaker Y</p> | (4) | <p>beaker X beaker Y</p> |

14 The diagram below shows the human skeletal system.

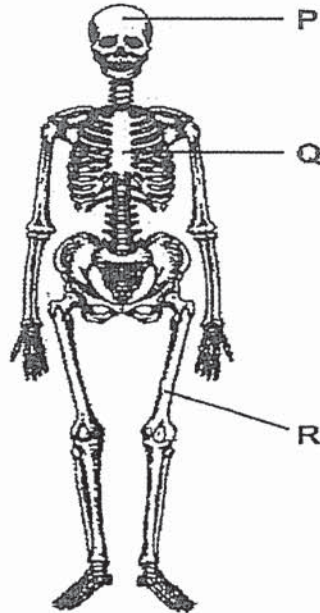

Which of the following statements about this system is/are true?

- P protects the brain
- Q protects the heart only
- R gives the body its shape

- (1) P and R only
- (2) P and Q only
- (3) Q and R only
- (4) P, Q and R

- 15 The diagram below shows the human digestive system with parts labelled A, B, C and D respectively.

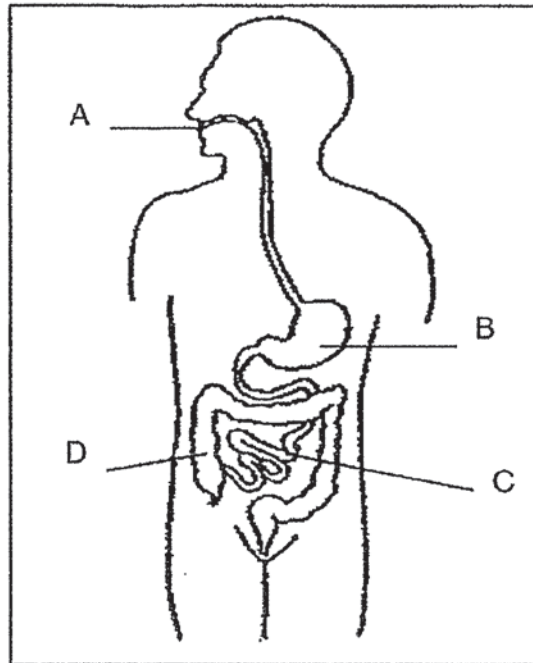

In which parts does digestion start and end respectively?

| | Start | End |
|-----|-------|-----|
| (1) | A | C |
| (2) | A | D |
| (3) | B | C |
| (4) | B | D |

16 The flow chart shows how animals P, Q and R, are grouped.

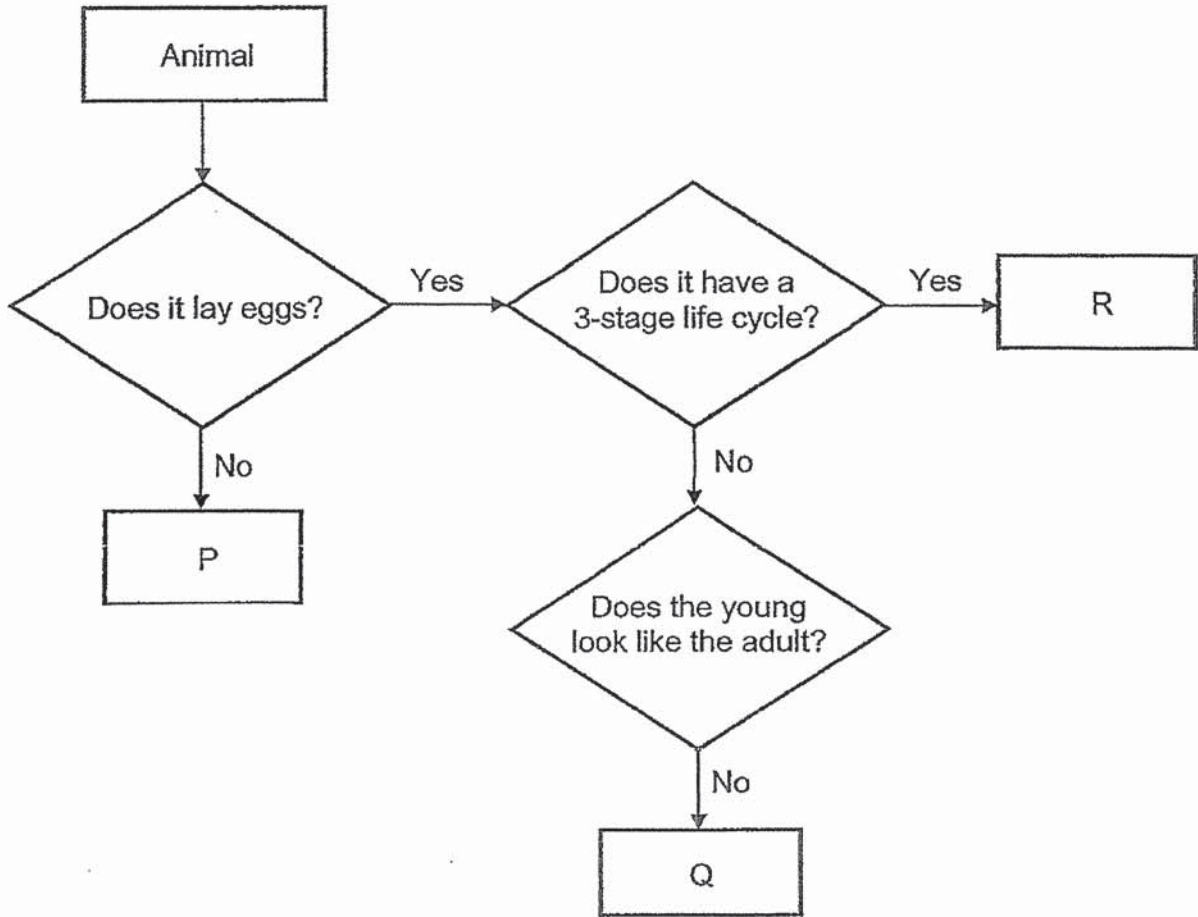

Based on the information given above, which one of the following best represents animals P, Q and R?

| | P | Q | R |
|-----|---------|-----------|-----------|
| (1) | tiger | mosquito | cockroach |
| (2) | tiger | cockroach | mosquito |
| (3) | chicken | cockroach | mosquito |
| (4) | chicken | mosquito | cockroach |

- 17 Siti wanted to find out which material, W, X, Y or Z, was the most suitable for making a swimming float. She placed the four materials of the same size and shape in a container of water as shown below.

Diagram 1 shows the positions of materials W, X, Y and Z in water.

Diagram 2 shows a boy using a swimming float.

Diagram 1:

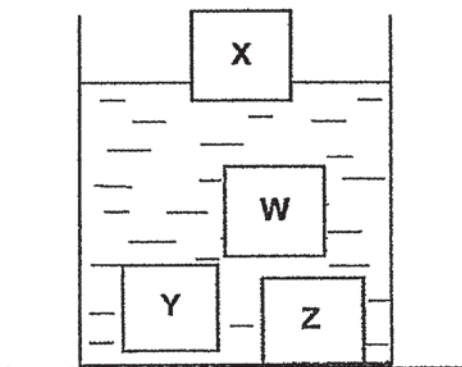

Diagram 2:



Based on the diagram above, which material, W, X, Y or Z, is the most suitable to make the swimming float?

- (1) W
- (2) X
- (3) Y
- (4) Z

- 18 Sarah carried out a flexibility test on four rods made of different materials, M, N, P and Q. She bent each rod with the same amount of strength. The distance 'd' showed how much each rod could bend.

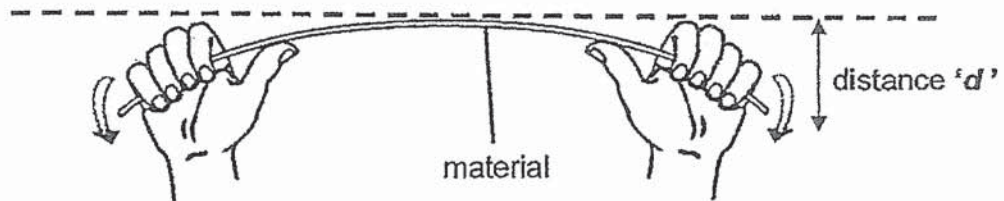

| Material | Distance 'd' (cm) |
|----------|-------------------|
| M | 3 |
| N | 1 |
| P | 9 |
| Q | 7 |

Based on the above results, which material is the most flexible?

- (1) M
- (2) N
- (3) P
- (4) Q

- 19 Mikka wanted to find out if the number of coils around an iron rod affects its magnetic strength. When the batteries and the iron rods are connected, the iron rod becomes magnetised.

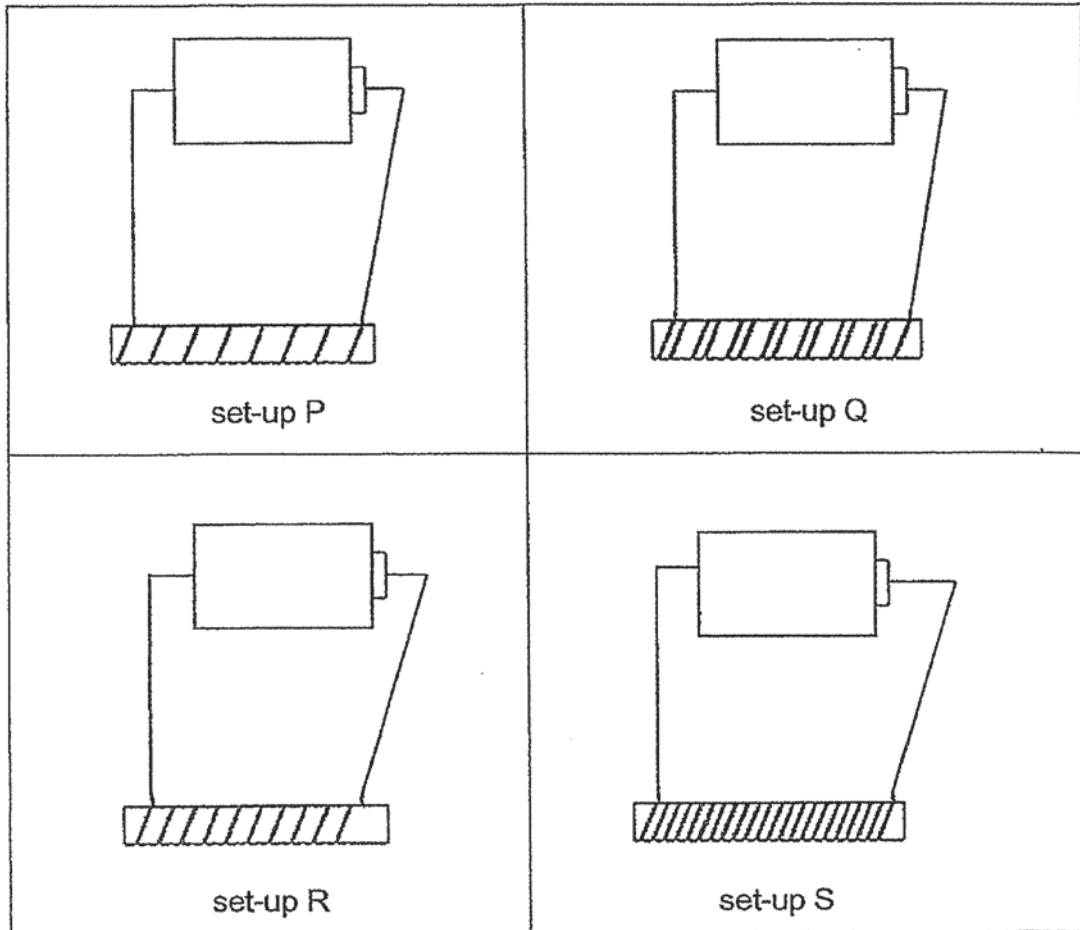

Which one of the following shows the correct arrangement of the magnetised rod according to their magnetic strengths, starting from the weakest to the strongest?

| | weakest \longrightarrow strongest | | | |
|-----|-------------------------------------|---|---|---|
| (1) | P | Q | R | S |
| (2) | P | R | Q | S |
| (3) | R | P | Q | S |
| (4) | S | Q | R | P |

- 20 Four identical bar magnets are arranged such that they are attracted to one another as shown below.

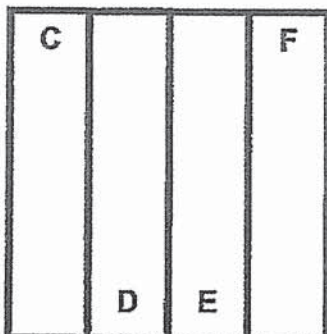

Given that end C is a north pole, what are the poles of D, E and F?

| | D | E | F |
|-----|--------|--------|--------|
| (1) | S-pole | S-pole | N-pole |
| (2) | S-pole | N-pole | N-pole |
| (3) | N-pole | N-pole | S-pole |
| (4) | N-pole | S-pole | S-pole |

- 21 The table shows the properties of three types of matter, C, D and E. A tick (✓) indicates that the matter has the property listed.

| Matter | Has definite shape | Has definite volume | Can be compressed |
|--------|--------------------|---------------------|-------------------|
| C | ✓ | ✓ | |
| D | | ✓ | |
| E | | | ✓ |

Which of the following shows the correct states of C, D and E?

| | C | D | E |
|-----|--------|--------|-------|
| (1) | solid | liquid | gas |
| (2) | liquid | solid | solid |
| (3) | gas | liquid | solid |
| (4) | gas | solid | gas |

- 22 Jane conducts an experiment. She made a hole in Can X and two holes in Can Y. When she poured out the condensed milk, she noticed that the condensed milk in Can Y flowed out faster than the condensed milk in Can X.

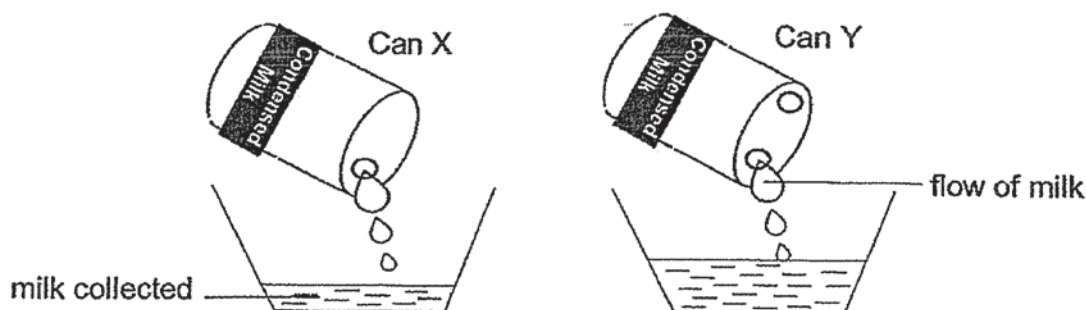

What could be a possible reason for this observation?

- (1) Condensed milk in Can X occupies more space.
 - (2) Some milk spilled out from the second hole in Can Y.
 - (3) Some milk became solid and could not come out of the hole in Can X.
 - (4) More air could enter Can Y thus occupying the space previously occupied by the milk.
- 23 A ball and a cube were lowered into two cans filled with water as shown in Set-up 1 and Set-up 2 respectively. The water that overflowed was collected in the measuring cylinders as shown below.

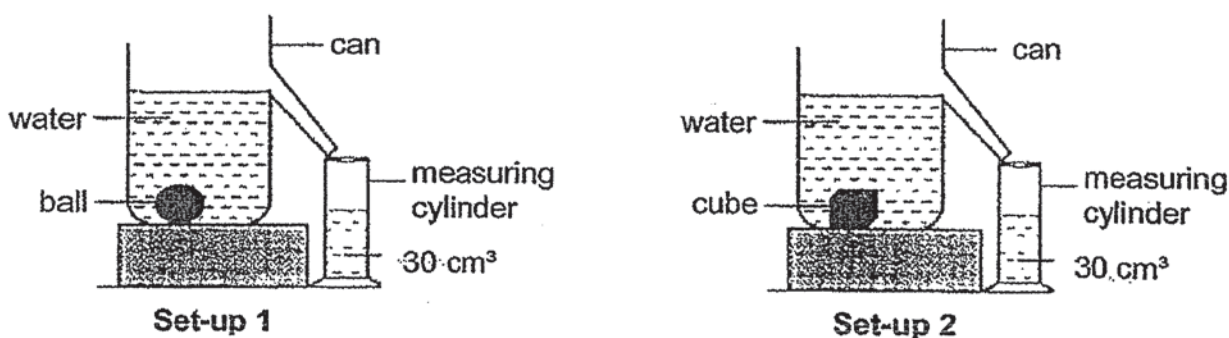

This activity shows that both the ball and cube have the _____.

- (1) same mass
- (2) same volume
- (3) same mass and volume
- (4) same mass but different states

24 The diagram below shows a man walking on the street at night.

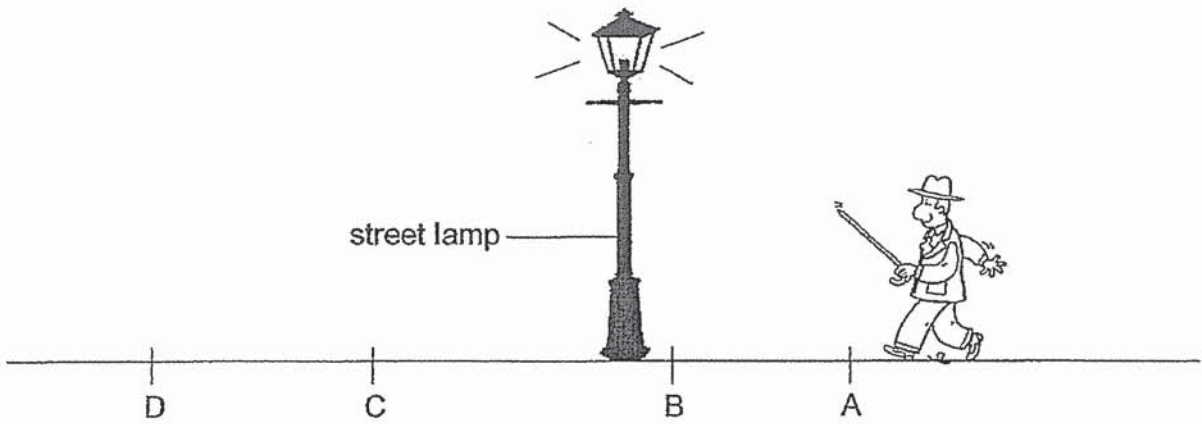

Which one of the following graphs shows how the length of the man's shadow changes from A to D under the lit street lamp?

(1)

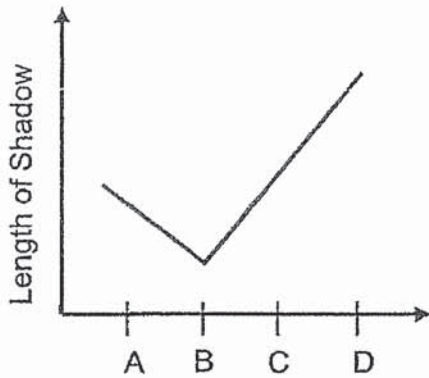

(2)

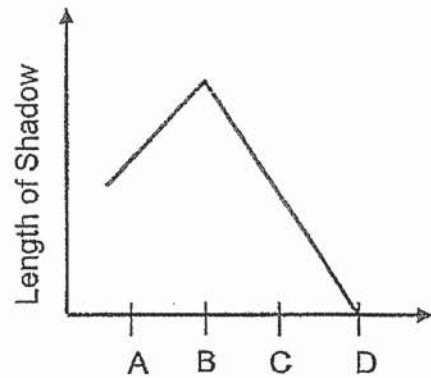

(3)

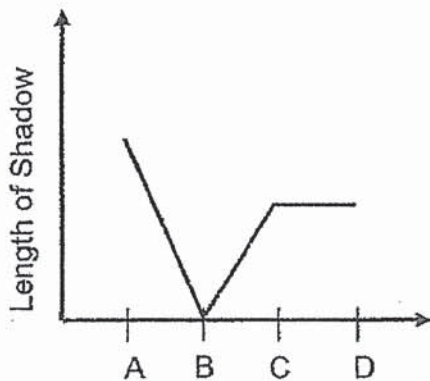

(4)

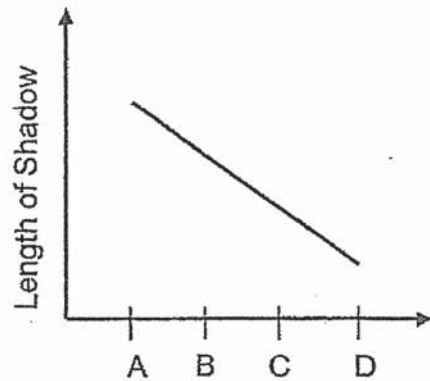

25. Justin cut out a circle and a square from each metal sheet as shown below.

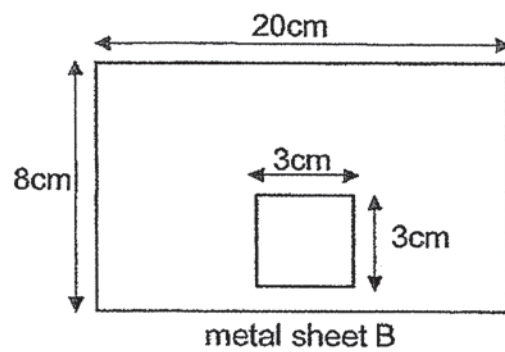
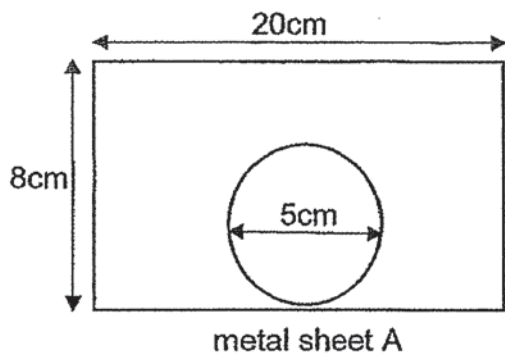

He then glued both rectangular sheets together and placed them between a torch and a screen and conducted the experiment in a dark room as shown below.

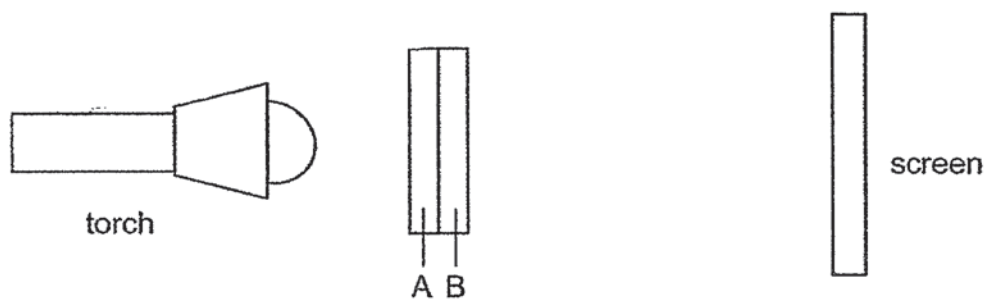

Which of the following could be the shadow cast on the screen?

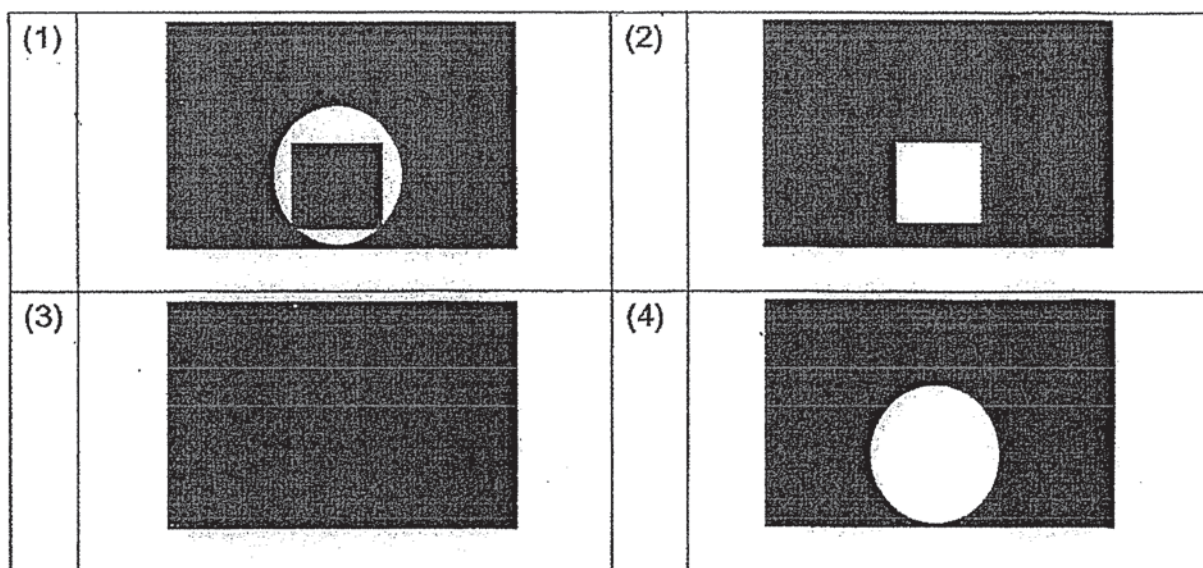

26 Object Q was placed behind object P as shown in the diagram below.

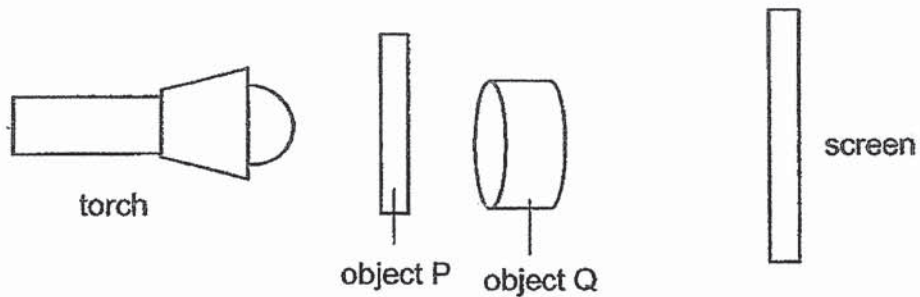

The properties of the objects P and Q are shown in the table below.

| Object | Shape of object | Does the object allow any light to pass through? |
|--------|-----------------|--|
| P | | Some |
| Q | | No |

Which one of the following diagrams shows correctly the shadow cast on the screen?

| | | | |
|-----|--|-----|--|
| (1) | | (2) | |
| (3) | | (4) | |

- 27 Ellie poured some water into container X, Y and Z as shown below. All 3 containers are identical and they are placed in the same room as shown below.

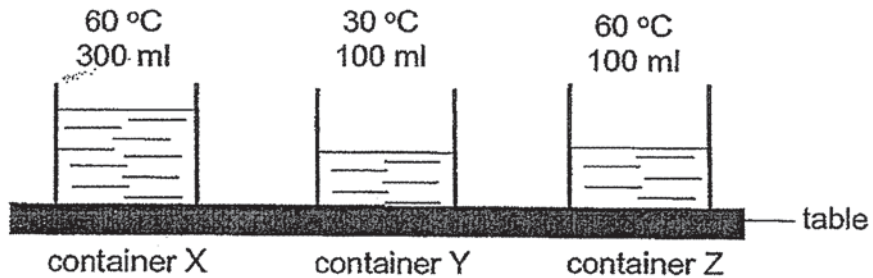

Which two statements are correct? .

- A Water in Container X has the most amount of heat.
 - B Water in Container X and Container Z have the same amount of heat.
 - C Water in Container Z has more heat than water in Container Y.
 - D Water in all three containers have the same amount of heat.
- (1) A and B
(2) A and C
(3) B and C
(4) C and D

28 There were gaps between the concrete slabs on the pavement in the park.

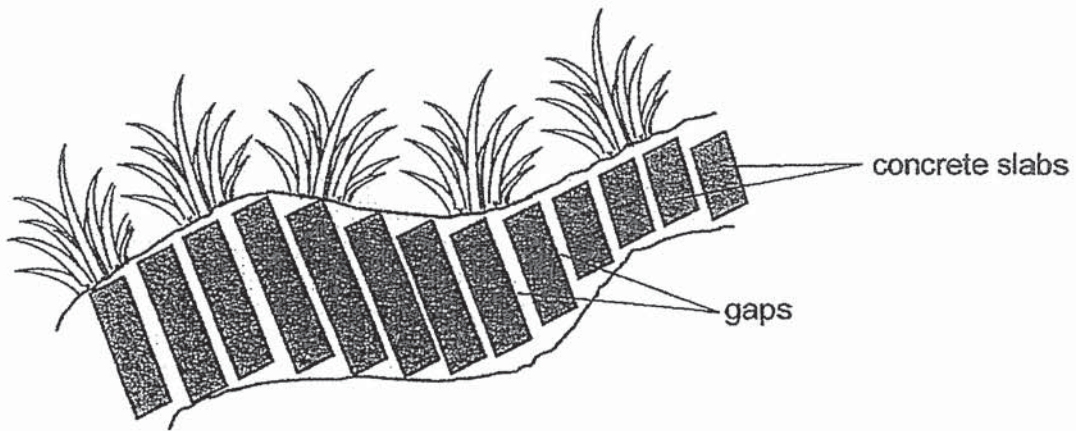

What is the purpose of these gaps?

- (1) to allow the concrete slabs to look beautiful
- (2) to allow the concrete slabs to dry faster after rain
- (3) to allow for expansion of concrete slabs on a hot day
- (4) to allow for contraction of the concrete slabs on a cold day



**NAN HUA PRIMARY SCHOOL
END-OF-YEAR EXAMINATION 2020
PRIMARY 4**

SCIENCE

BOOKLET B

13 Open-ended questions (44 marks)

Total Time for Booklets A and B: 1 hour 45 minutes

INSTRUCTIONS TO CANDIDATES

1. Write your name and index number in the space provided.
2. Do not turn over the page until you are told to do so.
3. Follow all instructions carefully.
4. Answer all questions.
5. Write your answers in this booklet.

Marks Obtained

| | | |
|------------------|--|-------------|
| Section B | | / 44 |
|------------------|--|-------------|

Name: _____ () **Class: P 4** _____

Date: 28 October 2020

Parent's Signature: _____

Section B: (44 marks)

Write your answers to questions 29 to 41 in the space provided.

The number of marks allocated is shown in brackets [] at the end of each question or part of the question.

29 Study the diagram below.

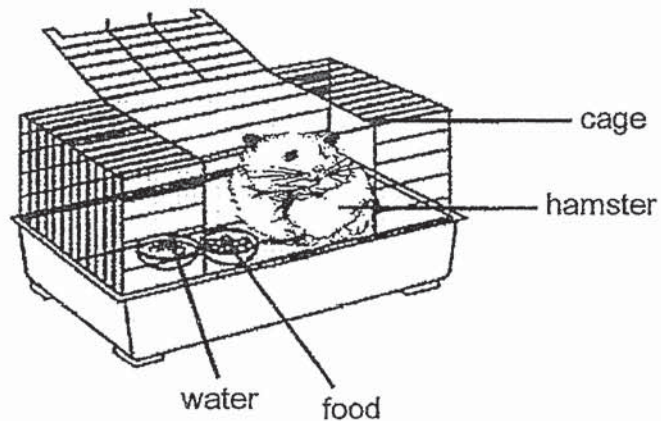

(a) After five days, will the amount of water in the bowl increase, decrease or remain the same? _____ . [1]

(b) Based on the diagram above, other than food, name another substance this hamster needs so that it remains alive. [1]

(c) Sandy opened the cage and wanted to hold her pet hamster. However, the hamster moved away. What characteristic of living things does this show? [1]

| | |
|-------|---|
| Score | 3 |
|-------|---|

30 Sarah places a magnet near an iron nail. The iron nail moves towards the magnet.



(a) This shows that the magnet exerts a _____ on the iron nail. [1]

Choose the correct word from the box to answer the question below.

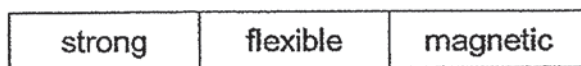

(b) Based on the experiment, Sarah can conclude that iron is a _____ material. [1]

Sarah then places the magnet onto a styrofoam board which she puts them in a pail of water. She spins the styrofoam board and it comes to a complete stop pointing in a certain direction.

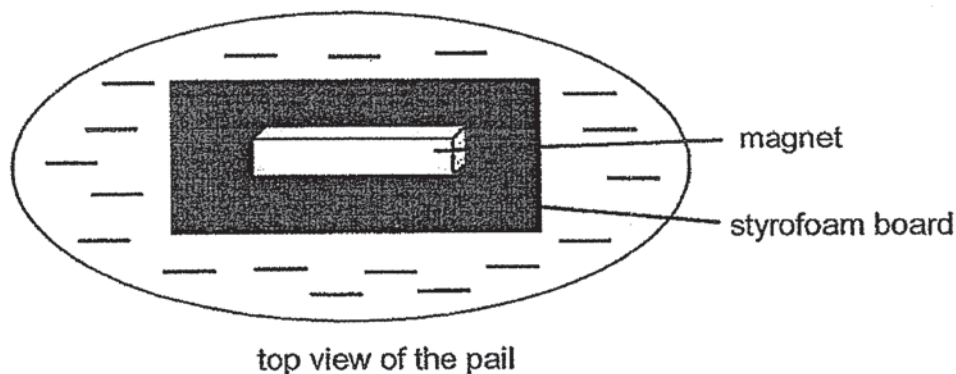

(c) In which direction will the magnet come to a rest? [1]

| | |
|-------|---|
| Score | 3 |
|-------|---|

31 Choose the correct words from the box to fill in the blanks below.

| | | |
|-------|--------|-----|
| solid | liquid | gas |
|-------|--------|-----|

(a) Jennifer pours milk from a bottle onto a table as shown below.

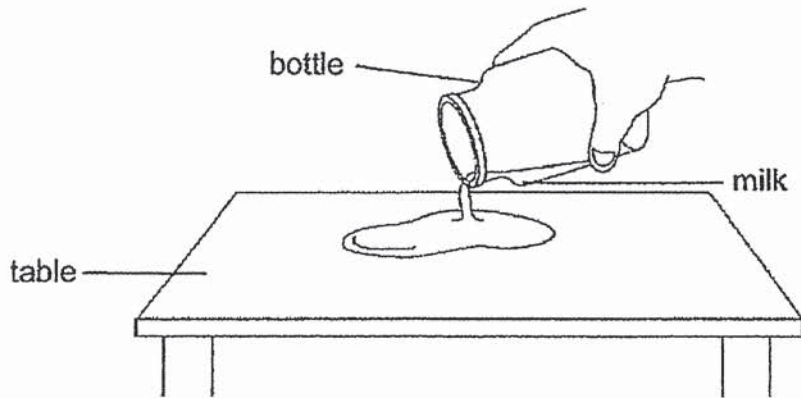

The volume of milk remains the same but its shape changes.

This shows that milk is a

[1]

(b) Jennifer pours some small balls from a bottle onto a table as shown below.

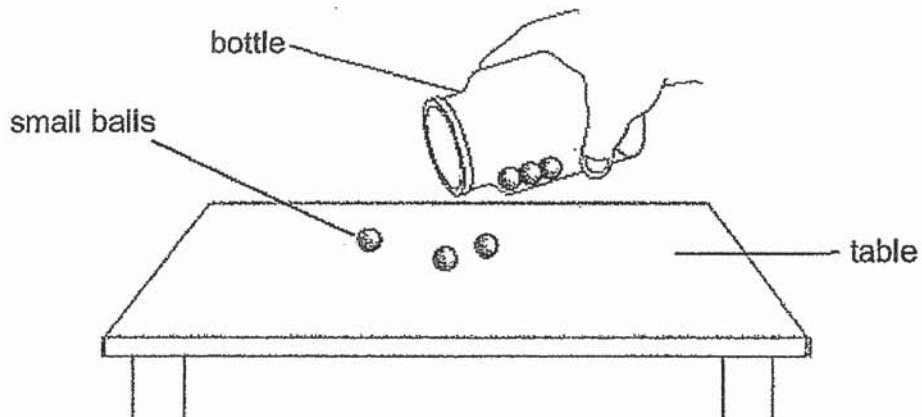

The shape and volume of the small balls remain the same.

This shows that a marble is a _____ .

[1]

| | |
|-------|---|
| Score | 2 |
|-------|---|

32 The diagram shows how Jamie sees a sofa in the living room.

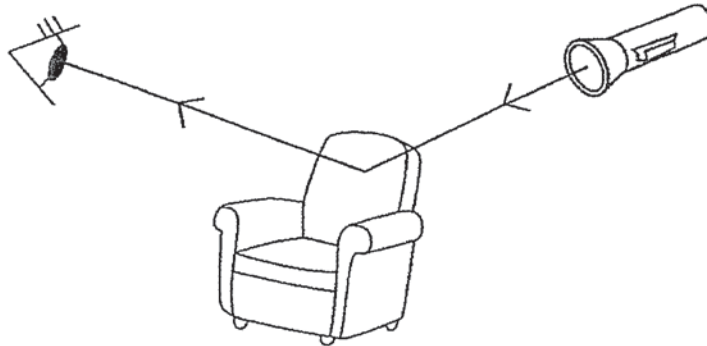

Fill in the blanks using the correct words in the box.

| | | | |
|----------|-------|-----------|--------|
| absorbed | house | reflected | source |
|----------|-------|-----------|--------|

(a) The torch is the light _____ [1]

(b) Light is _____ by the sofa into Jamie's eye. [1]

33 The diagram shows a beaker of warm water.

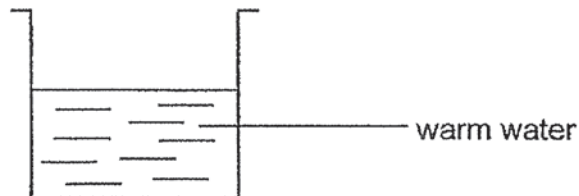

Fill in the blanks using the correct words in the box.

| | | |
|-----------|--------------------|-------|
| gas | decreases | solid |
| increases | remained unchanged | |

(a) When heat in the water is lost to the surroundings, its temperature _____ [1]

(b) The beaker of warm water is placed over a heat source. After some time, the water will change its state to become a _____ [1]

| | |
|-------|---|
| Score | 4 |
|-------|---|

- 34 Tara drew a model of the human digestive system and labelled the organs, A, B, C and D, as shown below.

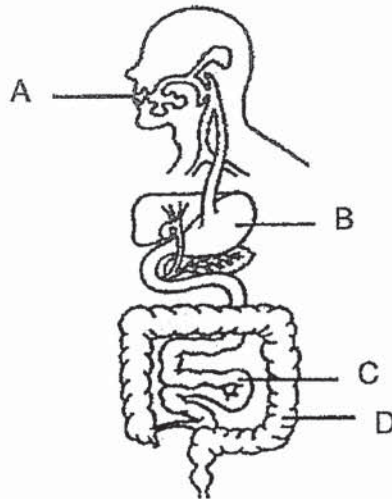

- (a) Name the organs, A, B, C and D, of the digestive system.

A: _____

B: _____

C: _____

D: _____

[2]

- (b) Explain how the chewing of food at Organ A helps in digestion.

[2]

| | |
|-------|---|
| Score | 4 |
|-------|---|

35 The diagrams below show the life cycle of the butterfly and the grasshopper.

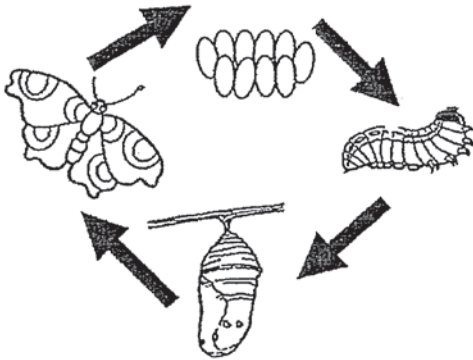

Life cycle of butterfly

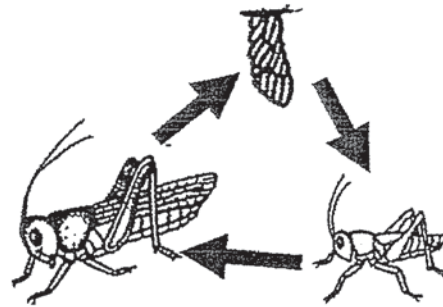

Life cycle of grasshopper

(a) How do the two animals reproduce?

[1]

(b) Based on the diagram above, state one **difference** between the life cycles of the butterfly and the grasshopper.

[1]

(c) Name another animal that goes through a similar life cycle as (i) the butterfly and (ii) the grasshopper.

[2]

(i) same as the butterfly: _____

(ii) same as the grasshopper: _____

| | |
|-------|---|
| Score | 4 |
|-------|---|

- 36 Sam carried out an investigation to find out the strength of four different strings made of materials P, Q, R and S. He set up the experiment as shown in the diagram below.

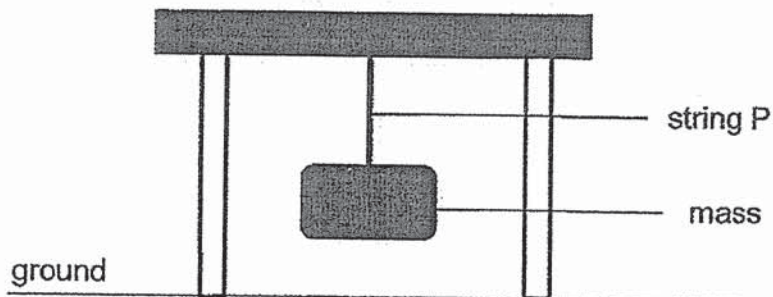

He hung a mass of 50g and increased the mass on each string until it broke. He recorded his results as shown in the table below.

| String made of material | Mass hung on each string before it broke (g) |
|-------------------------|--|
| P | 200 |
| Q | 50 |
| R | 150 |
| S | 100 |

- (a) What is the relationship between the strength of the string and the mass hung on each string before it broke? [1]

- (b) Based on Sam's results, arrange the materials, P, Q, R and S, in order of their strengths, starting with the weakest. [1]

weakest \longrightarrow strongest

, , ,

Continue on the next page \rightarrow

- (c) Sam claimed that Material Q is the most suitable to make into a bag that can hold items with a total mass 90g. Do you agree with him? Explain your answer. [2]

| | |
|-------|---|
| Score | 4 |
|-------|---|

- 37 A magnet was hung on a retort stand. Jeremy moved the toy truck with an unknown object towards the magnet. Both the suspended magnet and the toy truck moved towards each other. The direction of the movement is represented by the arrows shown in the diagram below.

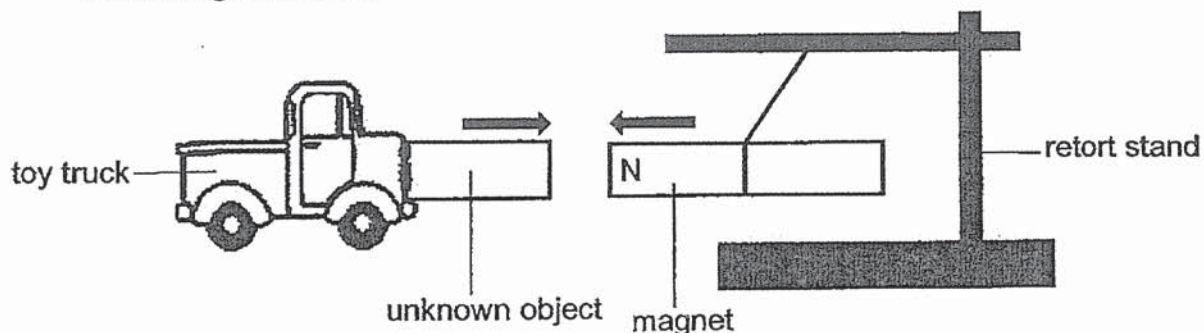

- (a) Based on the experiment, state one characteristic of the unknown material. [1]

- (b) Jeremy then turned over the suspended magnet and repeated the experiment as above. He realised that the toy truck moved away this time.

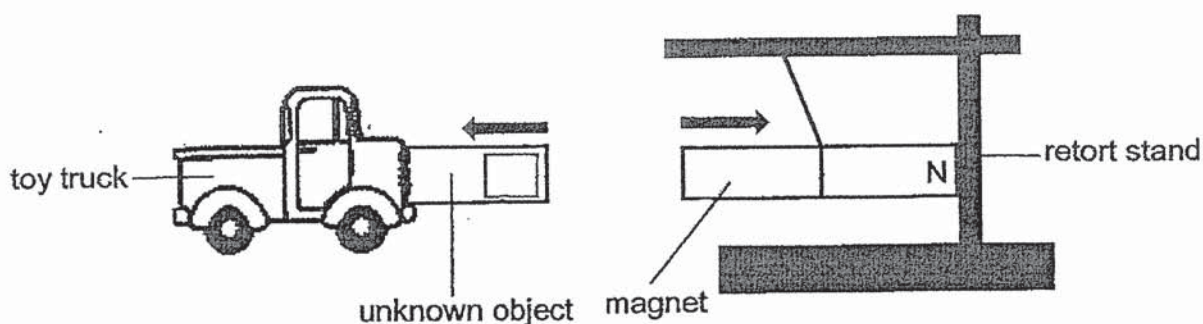

- (i) Jeremy concluded that the unknown object is a magnet. Explain why this is so. [2]

- (ii) Label the pole of the unknown object in the box in the diagram above. [1]

- 38 Ivan carried out an experiment to investigate the properties of air. He filled a cup of water and inverted it into a beaker of water as shown below.

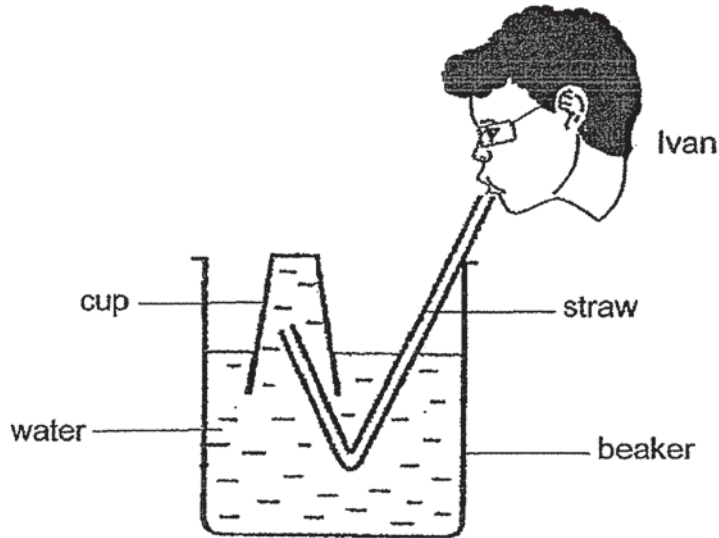

- (a) What will happen to the water level in the cup when air is blown into the cup through the straw? Explain your answer. [2]

Continue on the next page →

Ivan then carried out another experiment. A 500 cm^3 glass cylinder, containing 150 cm^3 of water, was connected to two syringes. One syringe was filled with 200 cm^3 of air and the other one had 50 cm^3 of water as shown in the diagram below.

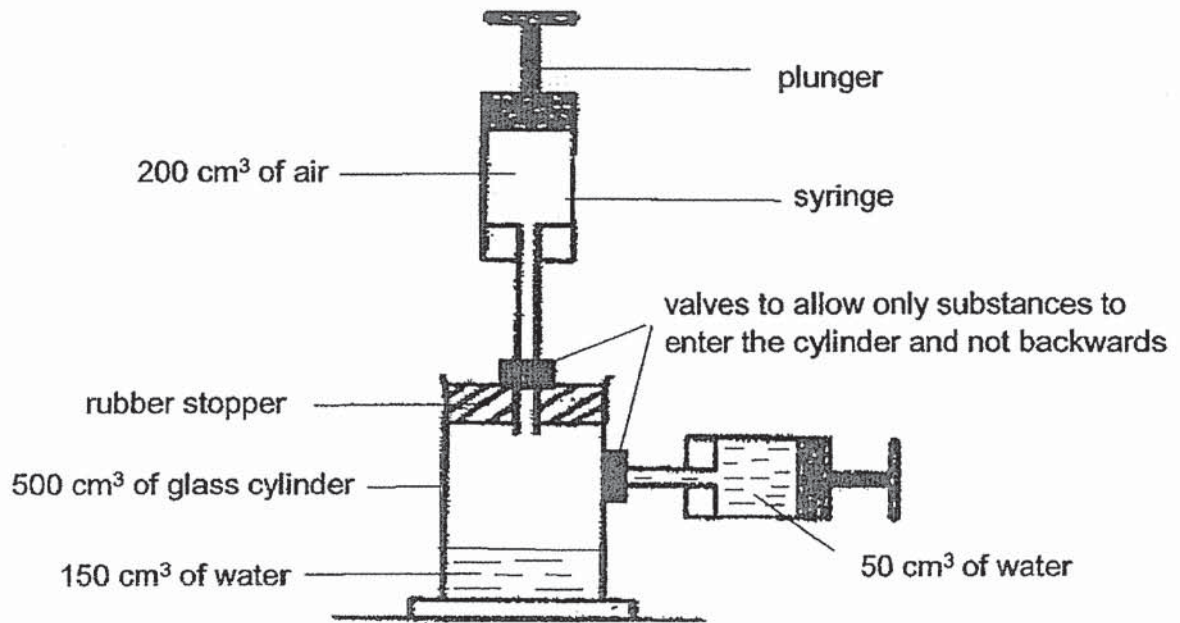

Both the air and water in the two syringes were emptied into the glass cylinder.

(b) What is the final volume of air in the glass cylinder? Using the properties of matter, explain why. [2]

| | |
|-------|---|
| Score | 4 |
|-------|---|

- 39 Justina filled a balloon with 200 cm^3 of water. She then tied a rubber band around the balloon as shown in the diagram below.

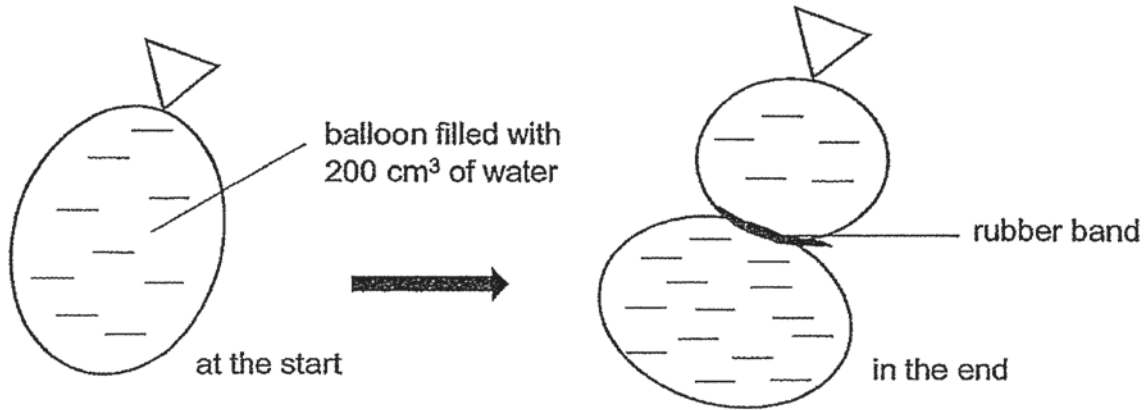

- (a) Did the volume of the water in the balloon change after it had been tied by the rubber band? Give a reason for your answer. [1]

- (b) What does the change in the shape of the balloon in the above tells you about the property of water? [1]

Continue on the next page →

Justina then conducted another experiment. She filled a syringe with some water as shown below. The nozzle of the syringe is tightly sealed.

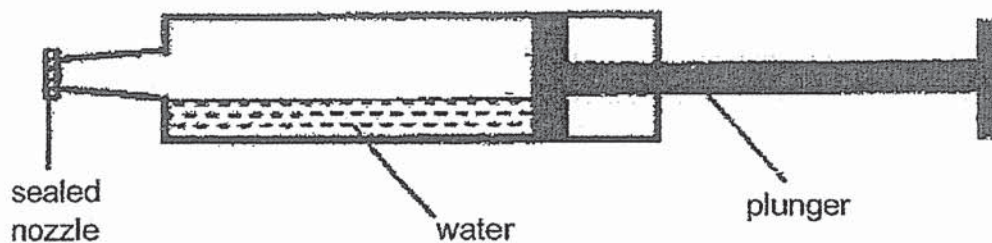

She pushed the plunger and discovered that the plunger could be pushed in slightly.

(c) Explain why the plunger could be pushed in slightly. [2]

| | |
|-------|---|
| Score | 4 |
|-------|---|

- 40 Julie wanted to find out which material, P, Q, R or S, blocks out the most amount of light. She placed each material, one at a time, in a black metal box and measured the amount of light detected by the light sensor attached to the datalogger as shown in the diagram below.

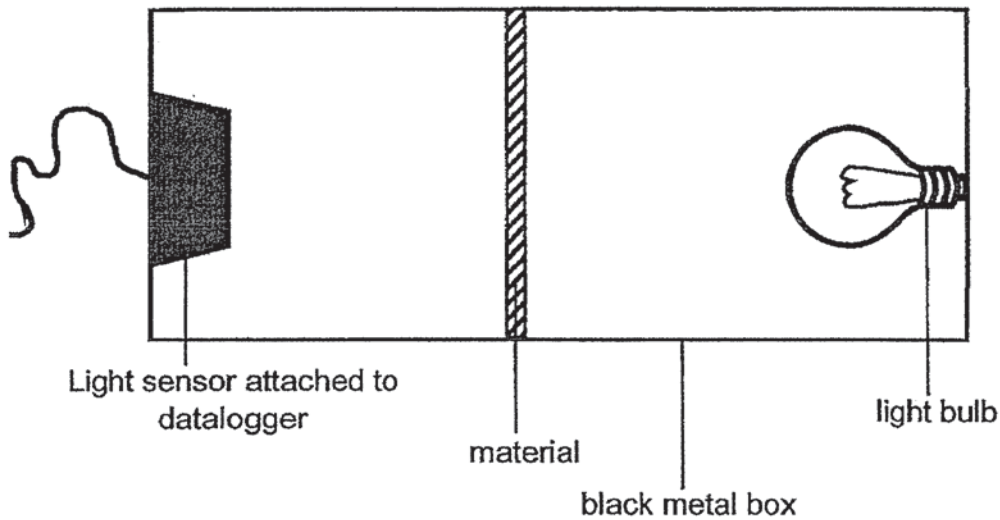

| Material | Amount of light detected (units) |
|----------|----------------------------------|
| P | 200 |
| Q | 180 |
| R | 150 |
| S | 0 |

- (a) Julie's house is undergoing renovation and she would need to choose a material to make her toilet door.

Which material should she choose that would best make her toilet door?

Explain your answer.

[2]

(b) Put a tick (✓) in the correct box to identify the **changed (independent) variable**, **measured (dependent) variable** and the **constant variables** in her experiment.

[2]

| | Variable that is changed (independent variable) | Variable that is measured (dependent variable) | Constant Variables |
|--|--|---|--------------------|
| Type of materials used | | | |
| The thickness of the materials used | | | |
| The amount of light detected by the light sensor | | | |
| The amount of light shining from the torch | | | |

| | |
|-------|---|
| Score | 4 |
|-------|---|

- 41 Jesslyn attached a balloon to a bottle as shown in Figure 1 below. She then placed the bottle in a container of hot water.

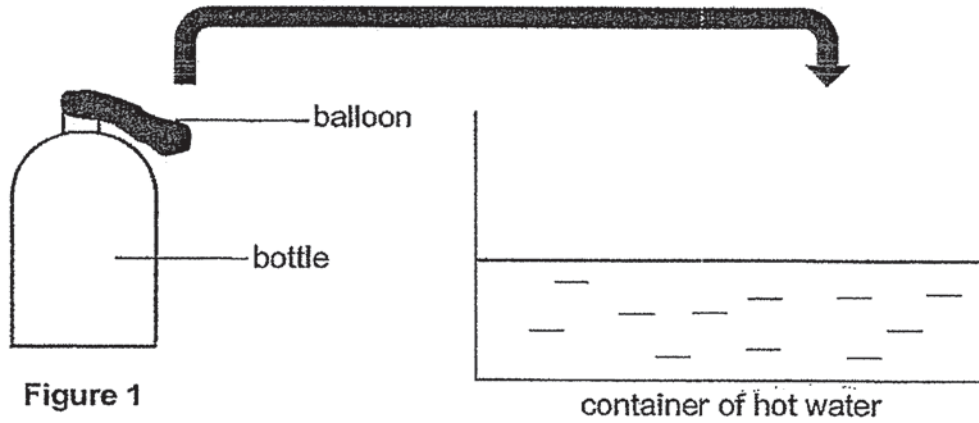

- (a) In the box provided below, draw what Jesslyn would observe of the balloon when the bottle is placed into the container containing hot water. [1]

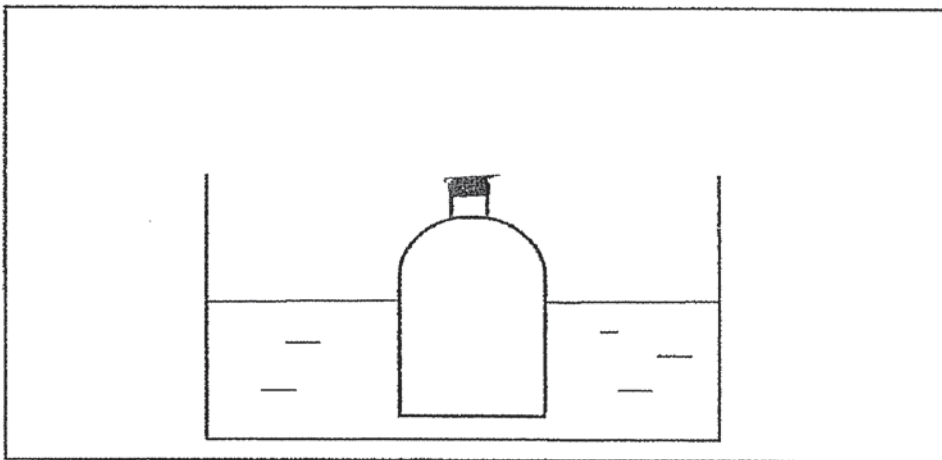

Continue to the next page →

Jesslyn did another experiment and this time, she placed the bottle in a container filled with ice cubes. After a while, the balloon was drawn into the bottle as shown in Figure 2 below.

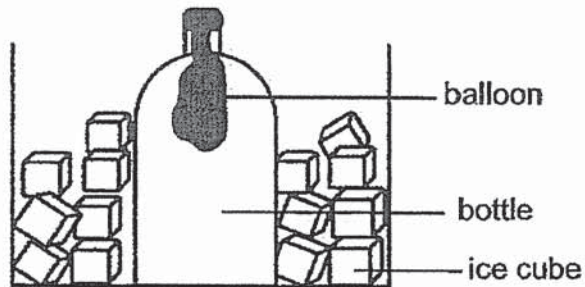
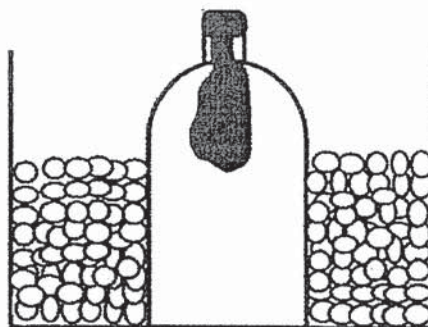

Figure 2

(b) Why was the balloon drawn into the bottle? [1]

Jesslyn then carried out the experiment again. This time, she placed the bottle into a container of crushed ice as shown below.



(c) Jesslyn observed that the balloon was drawn into the bottle more quickly. Explain why. [2]

End of paper

| | |
|-------|---|
| Score | 4 |
|-------|---|

ANSWER KEY

YEAR : 2020
LEVEL : PRIMARY 4
SCHOOL : NAN HUA
SUBJECT : SCIENCE
TERM : END-OF-YEAR

BOOKLET A

| | | | | | | | |
|-----|---|-----|---|-----|---|-----|---|
| Q1 | 4 | Q2 | 3 | Q3 | 3 | Q4 | 4 |
| Q5 | 3 | Q6 | 4 | Q7 | 1 | Q8 | 4 |
| Q9 | 4 | Q10 | 2 | Q11 | 1 | Q12 | 2 |
| Q13 | 4 | Q14 | 1 | Q15 | 1 | Q16 | 1 |
| Q17 | 2 | Q18 | 3 | Q19 | 2 | Q20 | 4 |
| Q21 | 1 | Q22 | 4 | Q23 | 2 | Q24 | 1 |
| Q25 | 2 | Q26 | 2 | Q27 | 2 | Q28 | 3 |

BOOKLET B

Q29 a) decrease

b) air / water

c) Living things respond to changes.

Q30 a) force

b) magnetic

c) North-South direction

Q31 a) liquid

b) solid

Q32 a) source

b) reflected

Q33 a) decreases

b) gas

Q34 a) A: mouth

B: Stomach

C: Small intestine

D: Large intestine

b) The teeth chew the food into smaller pieces and increase the surface area in contact with the digestive juices to digest the food into simpler substances faster.

ANSWER KEY
(STUDENT'S COPY)

| Qn | Answers |
|-----|---|
| 29a | decrease |
| 29b | air/water |
| 29c | Respond to changes/stimuli |
| 30a | pull /force |
| 30b | Magnetic |
| 30c | North-South direction/ North South direction |
| 31a | liquid |
| 31b | solid |
| 32a | source |
| 32b | reflected |
| 33a | decreases |
| 33b | gas |
| 34a | <p>A: Mouth</p> <p>B: Stomach</p> <p>C: Small intestine</p> <p>D: Large intestine</p> |
| 34b | <p>Chewing breaks food into smaller pieces so that more digestive juices can come into contact with the food/ food has a greater exposed surface area with more digestive juices to digest food faster.</p> |

| | |
|-----|---|
| 35a | <p>Both lay eggs.</p> <p style="text-align: center;">OR</p> <p>Both reproduce by laying eggs.</p> |
| 35b | <p>Butterfly has a 4-stage life cycle but grasshopper has a 3-stage life cycle. / Butterfly has a pupa stage but grasshopper does not have.</p> <p style="text-align: center;">OR</p> <p>The young of Y resembles the adult but the young of X does not resemble the adult.</p> |
| 35c | <p>Butterfly : Mosquito / Beetle</p> <p>Grasshopper : Cockroach / Chicken / Frog</p> |
| 36a | <p>As the strength of the string increases, the mass hung on the string before it started to break increases.</p> |
| 36b | <p>Q, S, R, P</p> |
| 36c | <p>No.</p> |
| | <p>The mass of weight hung on string made of material Q before it started to break is only 50g/the lowest/lightest.</p> <p>Material Q is the weakest hence handbag made of material Q will be least able to withstand/hold the mass of 90g and it will break.</p> |

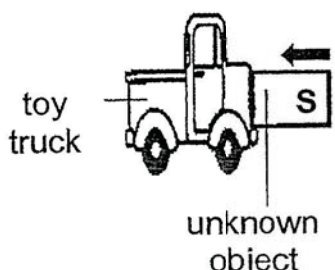
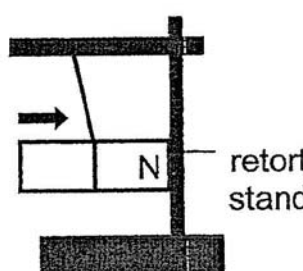
| | |
|---|---|
| <p>37a</p> <p>OR</p> <p>37bi</p> <p>37bii</p> | <p>It is magnetic.</p> <p>It is made of a magnetic material.</p> <p>The like poles of both objects are facing each other, so they repelled each other and only magnets can repel.</p> <div style="display: flex; justify-content: space-around; align-items: center;"> <div style="text-align: center;">  <p>toy truck</p> <p>unknown object</p> </div> <div style="text-align: center;">  <p>retort stand</p> </div> </div> |
| <p>38a</p> <p>38b</p> | <p>The water level in the cup decrease/drop/becomes lower.</p> <p>The air blown out by Ivan occupied the space previously occupied by the water in the inverted cup causing the water level to decrease.</p> <p>$500 \text{ cm}^3 - 200 \text{ cm}^3 = 300 \text{ cm}^3$</p> <p>300 cm³ of air. Water has a definite volume while air does not. Air will take up the remaining space inside/volume of the glass cylinder.</p> |
| <p>39a</p> <p>39b</p> <p>39c</p> | <p>No. Water has a definite volume.</p> <p>Water has no definite shape.</p> <p>As the air in the syringe can be compressed/no definite volume, the plunger can be pushed in slightly.</p> <p>*must mention where the air is present in</p> |

40a

She should choose material S.
No light is detected by the light sensor.
Hence, the material is opaque /does not allow light to pass through/
blocked all the light so she could have her privacy when she is in the
toilet/so nobody can see her inside.

40b

| | IV | DV | CV |
|--|----|----|----|
| Type of materials used | ✓ | | |
| The thickness of the materials used | | | ✓ |
| The amount of light detected by the light sensor | | ✓ | |
| The amount of light shining from the torch | | | ✓ |

Hari Hita Primary School

KIASU
ExamPaper
Islandwide Delivery | Whatsapp: 09880003

41a



41b

Air in the bottle lost heat to the ice and contracted / occupies less space. This drew the balloon into the bottle.

41c

The crushed ice has a larger surface area in contact with the bottle/larger contact surface area with the bottle/greater exposed surface to the bottle, causing the air in the bottle to lose heat to the crushed ice more quickly and contract more quickly.