

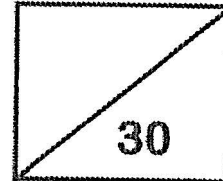

Rosyth School  
Topical Test 1  
Mathematics  
Primary 2



Name: \_\_\_\_\_

Class: Pr 2- \_\_\_\_\_ Register No.: \_\_\_\_\_

Duration: 40 min

Date: \_\_\_\_\_ Parent's Signature: \_\_\_\_\_

---

---

**Instructions to Pupils:**

1. Do not open this booklet until you are told to do so.
2. Follow all instructions carefully.
3. This paper consists of 2 parts, Sections A and B.
4. ANSWER ALL THE QUESTIONS.
5. Check all answers carefully.

	Maximum Marks	Marks Obtained
Section A	10	
Section B	20	
Total	30	

\* This paper consists of 6 printed pages altogether ( including cover page ).

This paper is not to be reproduced in part or whole without the permission of the Principal.

**SECTION A – (5 x 2 marks)**

There are 5 questions in this section.

Read the questions carefully. Choose the correct answer.

Write its number 1, 2, 3 or 4 in the brackets provided.

1) In 831, the value of the digit 8 is

(1) 8

(2) 80

(3) 100

(4) 800

( )

2) In 759, the digit  is in the tens place.

(1) 5

(2) 7

(3) 9

(4) 50

( )

3) Which one of the following has the smallest value?

(1) 526

(2) 256

(3) 625

(4) 265

( )

4)  $429 + 47 =$

(1) 382

(2) 466

(3) 476

(4) 899

( )

5) Subtract 2 tens from 536. The answer is

(1) 336

(2) 516

(3) 534

(4) 556

( )

---

**SECTION B – (10 x 2 marks)**

There are 10 questions in this section.

Read the questions carefully. Write your answer in the space provided.

Please show ALL your workings clearly.

6) Write seven hundred and ninety in numerals.

7) What is the number in the blank?

$$361 = 300 + \boxed{\phantom{000}} + 1$$

8) Complete the number pattern.

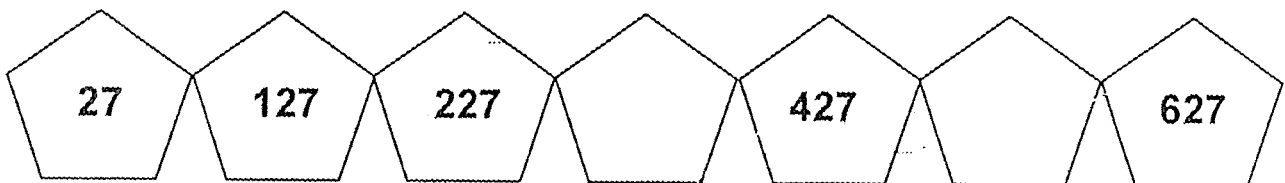

9) Use the three digits below to form the smallest number between 100 and 1000.

8

4

0

Use each digit once only.

10) Solve this addition equation.

$$\begin{array}{r} 1 \quad 2 \quad 3 \\ + 6 \quad 3 \quad 9 \\ \hline \\ \hline \end{array}$$

11) Solve this subtraction equation.

$$\begin{array}{r} 5 \quad 8 \quad 5 \\ - 1 \quad 6 \quad 7 \\ \hline \\ \hline \end{array}$$

12) Fill in the blanks.

$$\begin{array}{r} \square \quad \square \quad 6 \\ - 3 \quad 2 \quad 4 \\ \hline 3 \quad 1 \quad 2 \end{array}$$

13) Two numbers below give a total of 800.

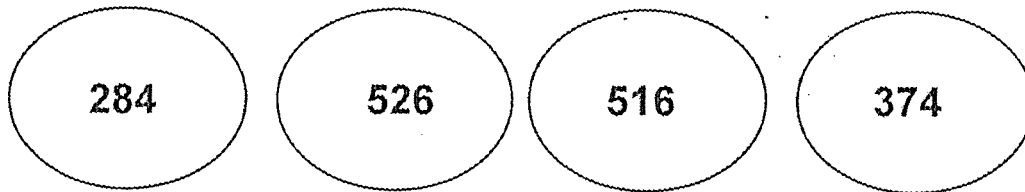

The two numbers are  and

14) Find the difference between 970 and 269.

15) Mary baked 243 cookies on Saturday. She baked 152 cookies on Sunday.

How many cookies did she bake altogether?

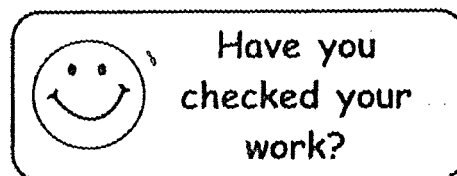

**-END OF PAPER-**



ROSYTH SCHOOL  
P2 HOLISTIC ASSESSMENT 2  
MATHEMATICS  
TOPICAL TEST

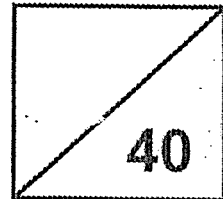

Name: \_\_\_\_\_

Class: Pr 2-\_\_\_\_\_ Register No. \_\_\_\_\_

Duration: 50 mins

Date: \_\_\_\_\_ Parent's Signature: \_\_\_\_\_

Instructions to Pupils:

1. Do not open this booklet until you are told to do so.
2. Follow all instructions carefully.
3. This paper consists of 3 parts, Sections A, B and C.
4. ANSWER ALL THE QUESTIONS.
5. Check all answers carefully.

	Maximum	Marks Obtained
Section A	12	
Section B	16	
Section C	12	
Total	40	

\* This paper consists of 9 printed pages altogether (including the cover page).  
This paper is not to be reproduced in part or whole without the permission of the Principal.

**SECTION A (6 x 2 marks)**

There are 6 questions in this section.

Read the questions carefully. Choose the correct answer.

Write its number 1, 2, 3 or 4 in the brackets provided.

---

1. 9 twos = \_\_\_\_\_

(1) 9

(2) 7

(3) 11

(4) 18

( )

---

2. 30 apples are packed equally into 5 bags.

There are \_\_\_\_\_ apples in each bag.

(1) 6

(2) 7

(3) 8

(4) 9

( )

---

3. The height of the classroom door is about \_\_\_\_\_.

(1) 2 cm

(2) 2 m

(3) 20 cm

(4) 20 m

( )

---



4.  $758 + 215 =$  \_\_\_\_\_

(1) 543

(2) 563

(3) 943

(4) 973

( )

---

5. 7 groups of 4 =  x 4

(1) 4

(2) 7

(3) 11

(4) 28

( )

---

6. A plate of chicken rice costs \_\_\_\_\_.



(1) \$ 2.30

(2) \$ 2.32

(3) \$ 4.20

(4) \$ 4.30

( )

---

**SECTION B (8 x 2 marks)**

There are 8 questions in this section.

Read the questions carefully. Write your answer in the box provided.

Show all your workings clearly.

7.

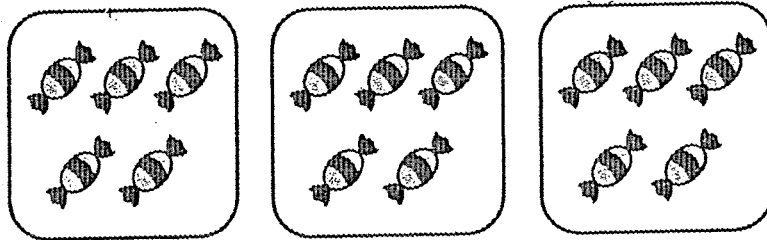

There are  groups of

8. Alice adds 3 numbers together to get 752.

Two of the numbers are 129 and 310.

What is the third number?

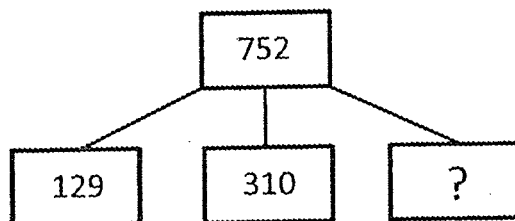

Ans:

9. Circle the most expensive item.



\$ 83.50



\$ 83.05



\$ 85.30

10. 12 cookies are placed onto 4 equal plates.  
How many cookies are there on each plate?

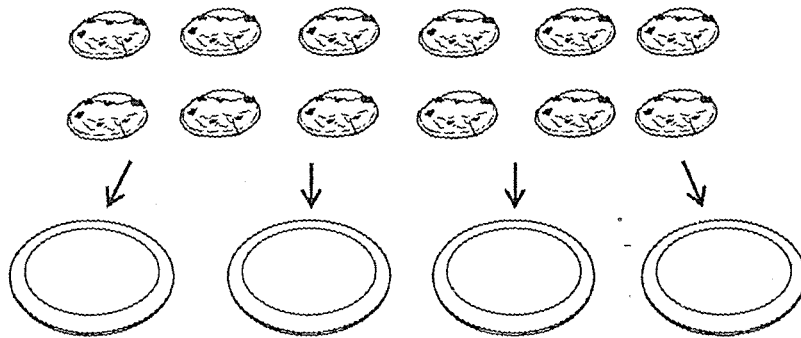

Ans:

Study the graph carefully.

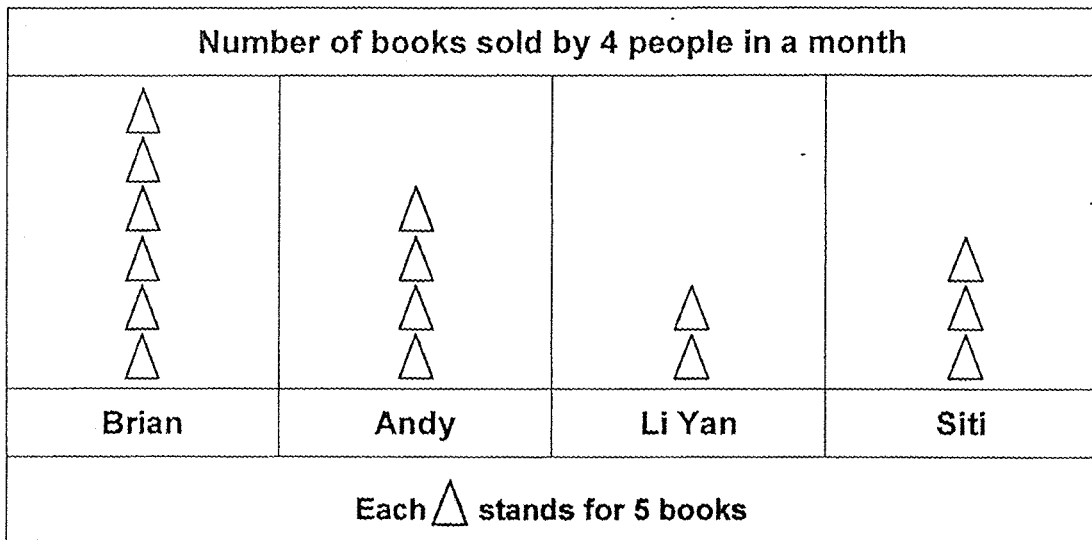

11. Siti sold  books in a month.

12. Brian sold  more books than Li Yan.

Study the picture below carefully.

Use the picture to answer questions 13 and 14.

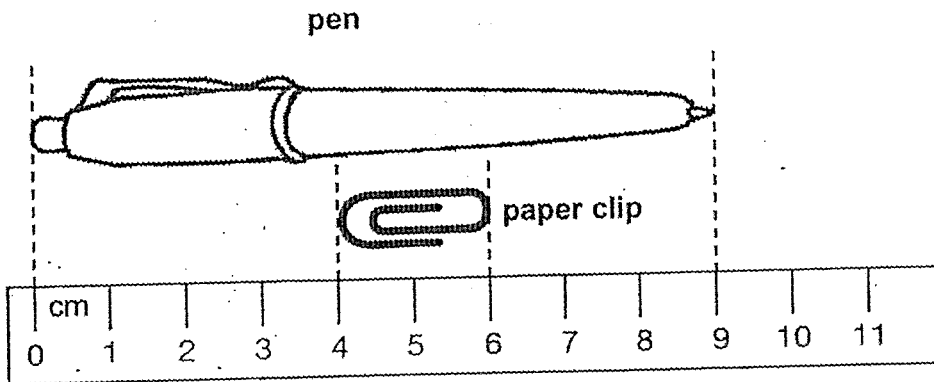

13. The length of the pen is \_\_\_\_\_.

Ans:            cm

---

14. The paper clip is \_\_\_\_\_ shorter than the pen.

Ans:            cm

---

**SECTION C** (3 x 4 marks)

There are 3 questions in this section.

Read the questions carefully. Write your number sentences.

Show all your workings clearly.

15. Ben bought a shirt and a watch.  
The watch cost \$93.  
The shirt cost \$42 less than the watch.
- (a) How much did the shirt cost?
  - (b) How much did he spend altogether?

Working

(a) The shirt cost \$ \_\_\_\_\_.

(b) Ben spent \$ \_\_\_\_\_ altogether.

16. There are 320 children.  
146 are boys and the rest are girls.

- (a) How many girls are there?
- (b) How many more girls than boys are there?

Working

(a) There are \_\_\_\_\_ girls.

(b) There are \_\_\_\_\_ more girls than boys.

17. Sam has 10 boxes of toys.

There are 4 toys in each box.

(a) How many toys are there altogether?

(b) He packs all the toys into bags of 5.

How many bags of toys are there?

(a) There are \_\_\_\_\_ toys.

(b) There are \_\_\_\_\_ bags.

---

End of paper  
Have you checked your work?  
Rosyth School





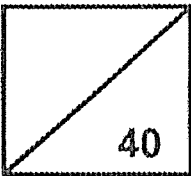

**ROSYTH SCHOOL  
HOLISTIC ASSESSMENT 3  
MATHEMATICS  
PRIMARY 2**

Total  40

Name: \_\_\_\_\_

Class: Pr 2- \_\_\_\_\_ Register No. \_\_\_\_\_ Duration: 50 minutes

Date: \_\_\_\_\_ Parent's Signature: \_\_\_\_\_

Instructions to Pupils:

1. Do not open this booklet until you are told to do so.
2. Follow all instructions carefully.
3. This paper consists of 3 parts, Sections A, B and C.
4. ANSWER ALL THE QUESTIONS.
5. Check all answers carefully.

	Maximum	Marks Obtained
<b>Section A</b>	<b>12</b>	
<b>Section B</b>	<b>16</b>	
<b>Section C</b>	<b>12</b>	
<b>Total</b>	<b>40</b>	

\* This paper consists of 11 printed pages altogether.

This paper is not to be reproduced in part or whole without the permission of the Principal.

**SECTION A (6 x 2 marks)**

Choose the correct answer and write its number in the brackets provided.

1. 4 threes = \_\_\_\_\_

(1) 7

(2) 12

(3) 43

(4) 4

(     )

---

2. What fraction of the figure shown below is shaded?

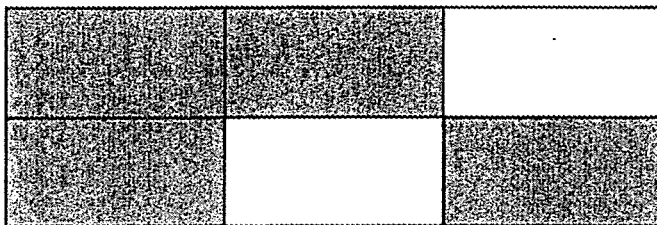

(1)  $\frac{2}{4}$

(2)  $\frac{2}{6}$

(3)  $\frac{4}{6}$

(4)  $\frac{6}{6}$

(     )

---

3.  $24 \div 3 =$  \_\_\_\_\_

(1) 6

(2) 7

(3) 8

(4) 9

( )

---

4. Ali mixed 5l of water and another 2l of syrup to make a drink. How many litres of drink did he make?



5l



2l

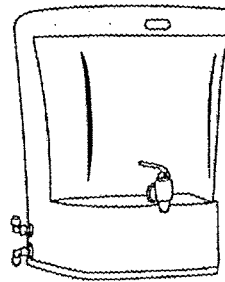
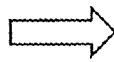

?

(1) 5 l

(2) 2 l

(3) 3 l

(4) 7 l

( )

5. The mass of the tin of cookies is \_\_\_\_\_ g.

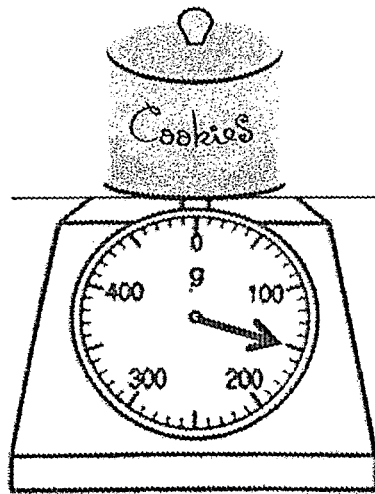

(1) 105

(2) 110

(3) 115

(4) 150

(       )

6. The mass of the toy car is \_\_\_\_\_ g.

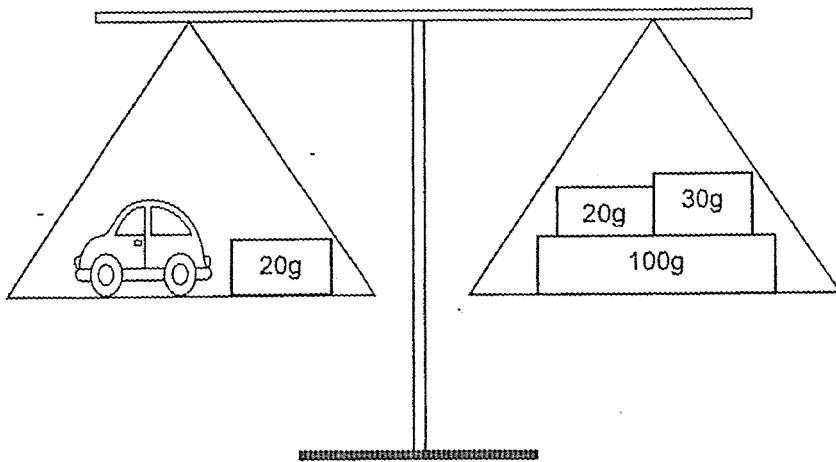

(1) 20

(2) 30

(3) 100

(4) 130

(            )

---

**SECTION B (8 x 2 marks)**

Read the questions carefully. Write your answer in the box provided.

Show ALL your workings clearly.

7. 9 groups of 4 =

Ans:

8. Circle the figure that is  $\frac{1}{3}$  shaded.

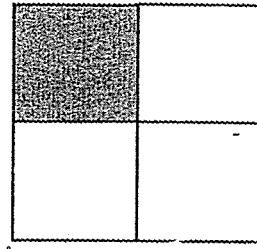
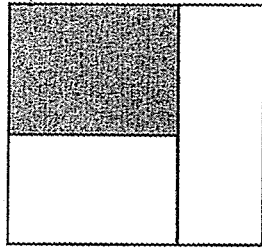
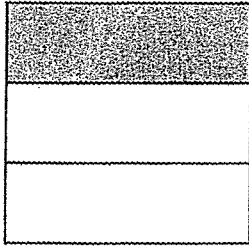

---

9. Find the sum of 367 and 422.

Ans:

10.  $\frac{2}{5}$  and  make 1 whole.

Ans:

11. Circle the cup that has a larger volume of water.

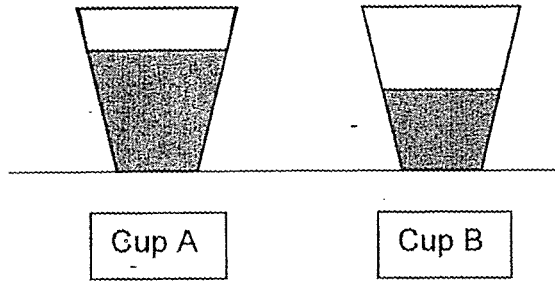

---

12. Jayne had 76 stickers.

She gave 48 stickers to her sister.

How many stickers did she have left?

Ans:

13.

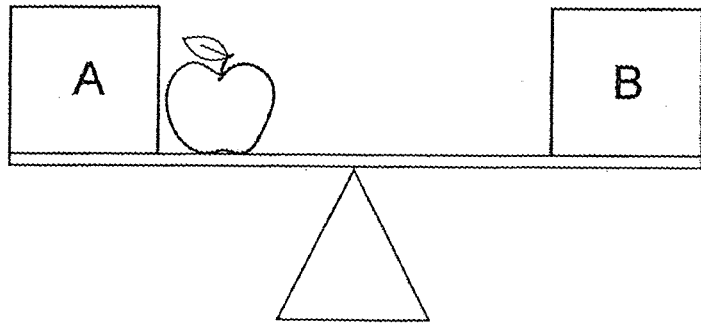

Box  is heavier than Box

---

14.

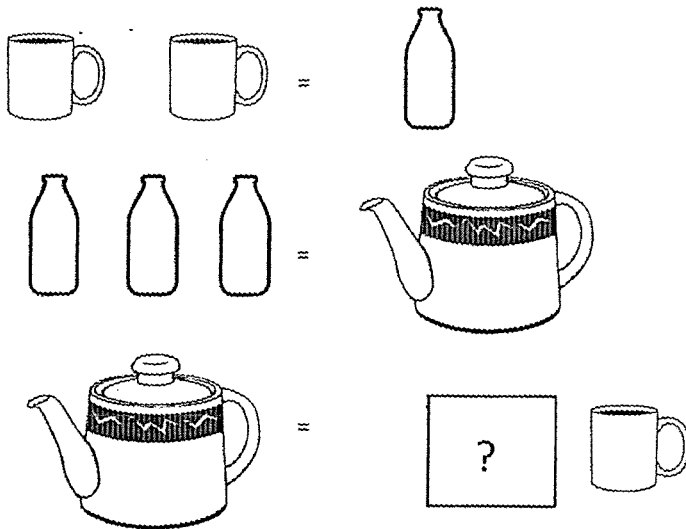

1 pot can fill   fully.

---



**SECTION C (3 x 4 marks)**

**Read the questions carefully.**

**Show all your number equations, workings and word statements clearly.**

15. Nancy baked 28 cupcakes.

She packed them equally into 4 boxes.

(a) How many cupcakes were there in each box?

(b) How many cupcakes were there in 3 boxes?

(a)

(b)

Working

16. The total mass of a stapler and a pencil box is 600g.

The stapler is 260g.

(a) What is the mass of the pencil box?

(b) What is the difference in mass between the pencil box and stapler?

Working

(a)

(b)

17. Andrew had some marbles at first.

He bought 35 marbles.

He then gave 110 marbles to his friend.

He had 145 marbles left.

How many marbles did he have at first?

Working

---

**End of paper**  
**Have you checked your work?**



## ANSWER KEY

LEVEL : PRIMARY 2  
SCHOOL : ROSYTH SCHOOL  
SUBJECT : MATHEMATICS  
TERM : TOPICAL TEST 1 , HOLISTIC ASSESSMENT 2 , HOLISTIC ASSESSMENT 3

### TOPICAL TEST 1

#### SECTION A

Q1	Q2	Q3	Q4	Q5
4	1	2	3	2

#### SECTION B

Q6) 790

Q7) 60

Q8)



Q9) 408

Q10) 762

Q11) 418

Q12)

$$\begin{array}{r} 636 \\ - 324 \\ \hline 312 \end{array}$$

Q13) The two numbers are 516 and 284

Q14) 701

Q15) 395

oo  
|

Handwritten numbers: 81612644, 93858586

### HOLISTIC ASSESSMENT 2

Q1	Q2	Q3	Q4	Q5	Q6
4	1	2	4	2	4

Q7) There are 3 groups of 5 .

Q8) 313

Q9)



Q10) 3

Q11) 15

Q12) 20

Q13) 9 cm

Q14) 7 cm

### SECTION C

Q15a) ( \$51 )

$$93 - 42 = 51$$

b) ( \$144 )

$$51 + 93 = 144$$

Q16a) ( 174 )

$$320 - 146 = 174$$

b) ( 28 )

$$174 - 146 = 28$$

Q17a) ( 40 )

$$10 \times 4 = 40$$

b) ( 8 )

$$40 \div 5 = 8$$

### HOLISTIC ASSESSMENT 3

Q1	Q2	Q3	Q4	Q5	Q6
2	3	3	4	4	4

#### SECTION B

Q7) 36

Q8)

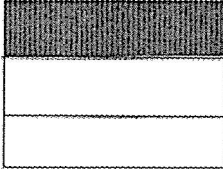

Q9) 789

Q10)  $\frac{3}{5}$

Q11) Cup A

Q12) 28

Q13) Box B is heavier than Box A

Q14) 6

#### SECTION C

Q15)a) (7)

$$28 \div 4 = 7$$

b) (21)

$$7 \times 3 = 21$$

Q16)a) (340g)

$$600 - 260 = 340$$

b) (80g)

$$340 - 260 = 80$$

Q17) (220)

$$145 + 110 = 255$$

$$255 - 35 = 220$$

THE END

